



(51) International Patent Classification:

C08L 67/02 (2006.01) C08L 51/04 (2006.01)  
C08L 69/00 (2006.01)

(21) International Application Number:

PCT/US2018/031387

(22) International Filing Date:

07 May 2018 (07.05.2018)

(25) Filing Language:

English

(26) Publication Language:

English

(30) Priority Data:

62/648,119 26 March 2018 (26.03.2018) US

(71) Applicant: **OCTAL, INC.** [US/US]; 5801 Tennyson Parkway, #450, Plano, TX 75024 (US).

(72) Inventors: **RAZEEM, Mohammed**; Octal, Inc., 5801 Tennyson Parkway, #450, Plano, TX 75024 (US). **DEAR-**

**MITT, Chris**; Phantom Plastics LLC, 2 Denison Lane, Terrance Park, OH 45174 (US).

(74) Agent: **BENNS, Jonathan, M.** et al.; Maschoff Brenman, 1389 Center Drive, Suite 300, Park City, UT 84098 (US).

(81) Designated States (unless otherwise indicated, for every kind of national protection available): AE, AG, AL, AM, AO, AT, AU, AZ, BA, BB, BG, BH, BN, BR, BW, BY, BZ, CA, CH, CL, CN, CO, CR, CU, CZ, DE, DJ, DK, DM, DO, DZ, EC, EE, EG, ES, FI, GB, GD, GE, GH, GM, GT, HN, HR, HU, ID, IL, IN, IR, IS, JO, JP, KE, KG, KH, KN, KP, KR, KW, KZ, LA, LC, LK, LR, LS, LU, LY, MA, MD, ME, MG, MK, MN, MW, MX, MY, MZ, NA, NG, NI, NO, NZ, OM, PA, PE, PG, PH, PL, PT, QA, RO, RS, RU, RW, SA, SC, SD, SE, SG, SK, SL, SM, ST, SV, SY, TH, TJ, TM, TN, TR, TT, TZ, UA, UG, US, UZ, VC, VN, ZA, ZM, ZW.

(84) Designated States (unless otherwise indicated, for every kind of regional protection available): ARIPO (BW, GH, GM, KE, LR, LS, MW, MZ, NA, RW, SD, SL, ST, SZ, TZ,

(54) Title: POLYETHYLENE TEREPHTHALATE ALLOY HAVING TALC

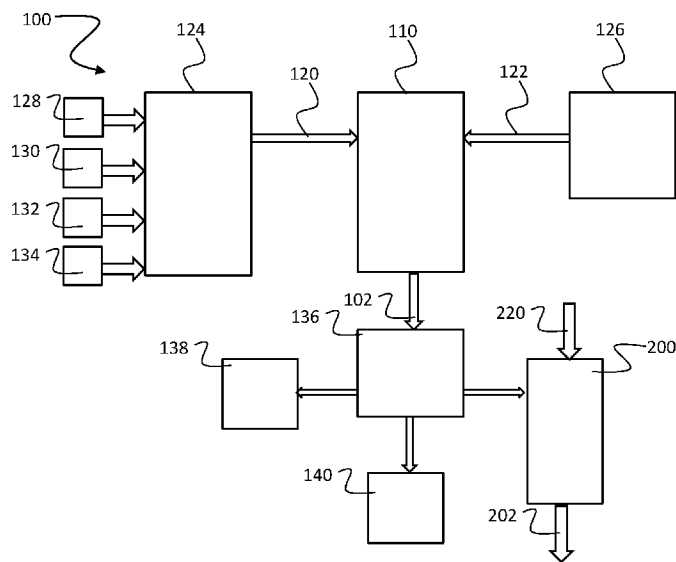

Fig. 1

(57) Abstract: A method of forming a polyethylene terephthalate (PET) mixture with talc includes: providing a feed of PET (PET feed); providing a feed of talc (talc feed); mixing the feed of PET with the feed of talc in a mixer at a PET:talc ratio of about 3:1 to about 1:3 to form a PET/talc mixture; and providing the PET/talc mixture as output. A method of forming a Polyethylene Terephthalate (PET) alloy having talc includes: providing a feed of the PET/talc mixture (PET/talc feed); providing a feed of PET (PET feed); mixing the feed of PET with the feed of PET/talc in a mixer to form a PET alloy having from about 1% (w/w) talc to about 50% talc (w/w); and providing the PET alloy as output.



UG, ZM, ZW), Eurasian (AM, AZ, BY, KG, KZ, RU, TJ, TM), European (AL, AT, BE, BG, CH, CY, CZ, DE, DK, EE, ES, FI, FR, GB, GR, HR, HU, IE, IS, IT, LT, LU, LV, MC, MK, MT, NL, NO, PL, PT, RO, RS, SE, SI, SK, SM, TR), OAPI (BF, BJ, CF, CG, CI, CM, GA, GN, GQ, GW, KM, ML, MR, NE, SN, TD, TG).

**Published:**

— *with international search report (Art. 21(3))*

## POLYETHYLENE TEREPHTHALATE ALLOY HAVING TALC

## CROSS-REFERENCE

The present application claims priority to U.S. Provisional Application No. 62/648,119 filed March 26, 2018, which provisional application is incorporated herein by specific  
 5 reference in its entirety.

## BACKGROUND

Polyethylene Terephthalate (PET) is a crystallizable polymer, which crystallization influences many properties, such as clarity, stiffness and strength of the PET product. The high molecular weight of commercial PET leads to poor flow properties, which  
 10 precludes the manufacture of thin-walled injection molded parts with PET. PET has a slow crystallization, which leads to long cycle times that are not commercially viable. Furthermore, PET has a low heat distortion temperature (HDT), such that the PET article can soften at relatively low temperatures.

A PET polymer having better flow, faster crystallization, and higher HDT while  
 15 maintaining the good properties of PET is desirable.

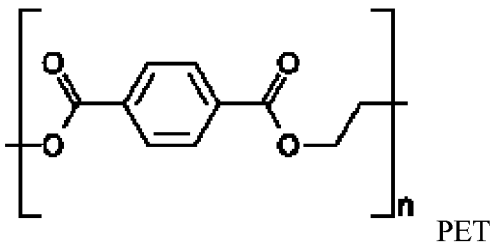

## SUMMARY

In one embodiment, a method of forming a polyalkylene terephthalate (PAT) (e.g., Polyethylene Terephthalate (PET)) mixture with talc is provided. The method can  
 20 include: providing a feed of PAT (PAT feed); providing a feed of talc (talc feed); mixing the feed of PAT with the feed of Talc in a mixer at a PAT:talc ratio of about 3:1 to about 1:3 to form a PAT/talc mixture; and providing the PAT/talc mixture as output.

In one embodiment, a system for forming a Polyalkylene Terephthalate (PAT) mixture with talc is provided. The system can include: a feed of PAT (PAT feed); a feed of talc  
 25 (talc feed); and a mixer coupled to an outlet of the PAT feed and coupled to an outlet of the talc feed, wherein the mixer is capable of mixing PAT with Talc at a PAT:talc ratio of about 3:1 to about 1:3 to form a PAT/talc mixture.

In one embodiment, a method of forming a Polyalkylene Terephthalate (PAT) alloy having talc is provided. The method can include: providing a feed of PAT (PAT feed);

providing a feed of PAT/talc (PAT/talc feed); mixing the feed of PAT with the feed of PAT/talc in a mixer to form a PAT alloy having from about 1% (w/w) talc to about 50% talc (w/w); and providing the PAT alloy as output.

In one embodiment, a system for forming a Polyalkylene Terephthalate (PAT) alloy having talc is provided. The system can include: a feed of PAT (PAT feed); a feed of PAT/talc (talc feed); a mixer coupled to an outlet of the PAT feed and coupled to an outlet of the PAT/talc feed, wherein the mixer is capable of mixing PAT with PAT/talc to form a PAT alloy having from about 1% (w/w) talc to about 50% talc (w/w).

In one embodiment, a polyalkylene terephthalate/talc (PAT/talc) mixture can include: polyalkylene terephthalate (PAT) containing talc at a PAT:talc ratio of about 3:1 to about 1:3.

In one embodiment, a polyalkylene terephthalate (PAT) alloy can include PAT having talc. The PAT can include: a first portion of PAT polymers having a first average molecular weight; a second portion of PAT polymers having a second average molecular weight, wherein the first average molecular weight is less than the second average molecular weight. The talc is in the PAT, wherein the talc is present in an amount of at least 1% and less than 50%.

In one embodiment, a mold system can include: a mold having a mold cavity; and a PAT alloy having PAT comprising a first portion of PAT polymers having a first average molecular weight and a second portion of PAT polymers having a second average molecular weight, wherein the first average molecular weight is less than the second average molecular weight, and talc in the PAT, wherein the talc is present in an amount of at least 1% and less than 50%, wherein the PAT alloy completely fills the mold cavity of the mold. The PAT can be:

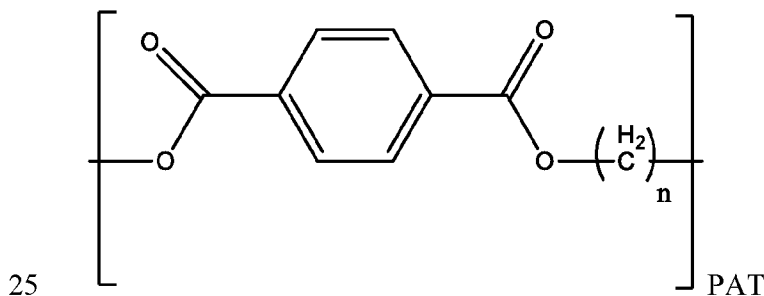

In the PAT, n may be any reasonable integer, such as 1 (Polymethylene Terephthalate (PMT)), 2 (Polyethylene Terephthalate (PET)), 3 Polypropylene Terephthalate (PPT), 4

(Polybutylene Terephthalate (PBT)), or 5 Polypentylene Terephthalate (PPentT), or the like (e.g., n is 6, 7, 8, 9, 10, etc.).

The foregoing summary is illustrative only and is not intended to be in any way limiting. In addition to the illustrative aspects, embodiments, and features described above, further aspects, embodiments, and features will become apparent by reference to the drawings and the following detailed description.

#### BRIEF DESCRIPTION OF THE FIGURES

The foregoing and following information as well as other features of this disclosure will become more fully apparent from the following description and appended claims, taken in conjunction with the accompanying drawings. Understanding that these drawings depict only several embodiments in accordance with the disclosure and are, therefore, not to be considered limiting of its scope, the disclosure will be described with additional specificity and detail through use of the accompanying drawings, in which:

- Figure 1 is a schematic representation of a system for preparing a PET/talc mixture.
- 15 Figure 2 is a schematic representation of a system for preparing a PET alloy having talc.
- Figure 3 is a schematic representation of a system for preparing a PET alloy into different articles, and optionally with additional optional components.
- Figure 4 is a schematic representation of an injection molding system for preparing a PET alloy into an injection molded article.
- 20 Figures 5A-5C show the relationship of flow and strength versus the PET polymer chain length.
- Figure 6A includes a graph that shows the differential scanning calorimetry DSC data for PET.
- Figure 6B includes a graph that shows the DSC data for PET having talc.
- 25 Figure 6C includes a graph that shows the DSC data for PET having talc formed at 110 °C.
- Figure 6D includes a graph that shows the DSC data for PET having talc formed at 120 °C.
- Figure 6E includes a graph that shows the DSC data for PET having talc formed at 125 °C.
- 30 Figure 6F includes a graph that shows the DSC data for PET having talc formed at 105 °C.
- Figure 7 includes a table showing properties of the PET alloy obtained by DSC.

Figure 8 includes a table showing oxygen permeability of the PET alloy.

Figure 9 includes a table showing properties of the PET alloy obtained by DSC.

Figure 10 includes a table showing the molar mass averages molecular weights for PET alloy and PET/talc.

- 5 Figure 11 includes a graph that shows the heat deformation temperature (HDT) of PET and PET alloys having various amounts of talc.

Figure 12 includes a table showing mechanical properties of the PET alloy further having chopped glass fiber (CGF).

Figure 13A includes a table showing mechanical properties for PET alloy.

- 10 Figure 13B includes a table showing mechanical properties of general purpose polystyrene (GPPS).

#### DETAILED DESCRIPTION

In the following detailed description, reference is made to the accompanying drawings, which form a part hereof. In the drawings, similar symbols typically identify similar  
15 components, unless context dictates otherwise. The illustrative embodiments described in the detailed description, drawings, and claims are not meant to be limiting. Other embodiments may be utilized, and other changes may be made, without departing from the spirit or scope of the subject matter presented herein. It will be readily understood that the aspects of the present disclosure, as generally described herein, and illustrated in  
20 the figures, can be arranged, substituted, combined, separated, and designed in a wide variety of different configurations, all of which are explicitly contemplated herein.

Generally, the present technology includes a system and method for preparing a Polyethylene Terephthalate (PET) alloy that includes talc. The PET alloy is formed with a system that prepares a PET/talc mixture, and then combines the PET/talc mixture with a  
25 PET composition to produce the PET alloy. Accordingly, the system and method can be used to produce a talc-filled PET (e.g., PET/talc mixture) that is manufactured in a precise manner, and which PET/talc mixture is then blended with PET (e.g., fresh PET, virgin PET, or PET without talc, etc.) to form a PET alloy material that has better flow characteristics, rapid crystallization, higher HDT and better barrier properties than PET,  
30 while maintaining the other desirable properties of PET, such as tensile strength and flexural yield strength.

PET can be favorable in products because of the water repellent and moisture barrier properties, which allows for PET alloy articles to be containers for liquid storage, such as

for beverages (e.g., soft drinks, water, beer, etc.). The high mechanical strength of the PET alloy can allow for use in tapes, such as a carrier for magnetic tape or a backing for pressure-sensitive adhesive tapes, or the like.

Now, the PET alloy can be modulated with the processing and amount of talc in the  
5 PET/talc mixture as well as the PET alloy to modulate the crystallization process, which allows for modulating clarity, stiffness and strength of the PET alloy product. The PET alloy can include low molecular weight PET mixed with talc and high molecular weight PET can leads to a faster or otherwise improved flow, and thereby now the PET alloy can be used in injection molding, such as for the manufacture of thin-walled injection molded  
10 parts, as well as extrusion to form a variety of extrudates, such as tales and fibers, and cylinders for pelletizing with a chopper. The PET alloy has a significantly shorter cycle time for crystallization, which allows for improved methods and uses for PET by using the PET alloy. Additionally, the PET alloy has a higher heat distortion temperature (HDT), which now allows the PET alloy to soften at significantly higher temperature  
15 compared to prior PET (e.g., non-alloy). Thus, the PET alloy provides a polymer having better flow, faster crystallization, and higher HDT. The improved systems and methods can now be used to produce a talc-filled PET (e.g., PET/talc mixture) manufactured in a precise manner, which PET/talc mixture is then blended with virgin PET (e.g., without talc) to form a PET alloy material which has better barrier properties, such as reduced  
20 oxygen permeability (see data in Figure 8). The data shows the PET alloy is a more effective barrier to gas permeability compared to standard unmodified PET. The data is expected to also show reduced permeability for carbon dioxide, water vapor and other gases. The improved barrier stems from increased crystallinity and the presence of talc, a platy, impermeable solid. These two changes reduce permeability to all types of  
25 penetrants.

The PET alloy may be formed into an amorphous (transparent) article, or a semi-crystalline article. The semi-crystalline material can appear transparent (e.g., when having particle size less than 500 nm) or opaque and white (e.g., when having particle size up to a few micrometers) depending on its crystal structure and particle size.

30 In one example, the PET feed material can be prepared by any suitable process. As generally known, the monomer bis(2-hydroxyethyl) terephthalate can be synthesized by the esterification reaction between terephthalic acid and ethylene glycol with water as a byproduct, or by transesterification reaction between ethylene glycol and dimethyl

terephthalate (DMT) with methanol as a byproduct. Polymerization is through a polycondensation reaction of the monomers (e.g., done immediately after esterification/transesterification) with water as the byproduct. The PET feed material can be prepared as described in U.S. 2009/0212457, which is incorporated herein by specific  
5 reference in its entirety. The PET feed material may be a sheet, pellet or other form as well as liquid PET. The PET feed material can be processed so that it is a liquid and flowable state for the methodologies described herein.

In one embodiment, a method of forming a polyethylene terephthalate (PET) mixture with talc is provided. Such a method can be performed with a PET/talc system 100, such  
10 as shown in Figure 1. The PET/talc system 100 for forming a PET mixture with talc can include: a feed of PET 120 (PET feed); a feed of talc 122 (talc feed); and a mixer 110 coupled to an outlet of the PET feed 120 and coupled to an outlet of the talc feed 122. The mixer 110 is capable of mixing PET with talc at a PET:talc ratio of about 3:1 to about 1:3 to form a PET/talc mixture or other ratio as desired. The system 100 can also include  
15 an output 136 operably coupled to an outlet of the mixer 110. The output 136 is selected from a container, pump, flow line, heater, cooler, extruder, die, pelletizer, mixer, and combinations thereof as well as other art-known components for PET systems. As shown, the system 100 can include the PET feed 120 having an inlet coupled to a PET supply 124.

20 It should be recognized that the PET may be substituted by PAT or any other type of PAT in the method and system 100. That is, the system may be configured for use with any PAT, and thereby the recitations of PET may also refer to PAT herein and for the other methods and other systems provided herein. For example, the PET/talc system 100 may be a PAT/talc system 100, and so on.

25 The system 100 may also include the talc feed 122 having an inlet coupled to a talc supply 126. The system 100 can include one or more of: a PET reactor system 128; a PET recycling system 130; a PET conditioning system 132; or a PET reservoir 134. The PET reactor system 128 is configured to polymerize the PET from PET precursor reagents. The PET recycling system 130 is configured to recycle the PET from PET  
30 articles. The PET conditioning system 132 is configured to condition the PET for mixing with talc, the conditioning selected from one or more of heating, chopping PET pellets or sheets or other PET member, agitating, extruding, drying; off-gassing, or the like. The PET reservoir 134 includes liquid PET, wherein the liquid PET is melted PET.



The system 100 can include the talc supply 126 having talc powder in a flowable format. The flowable format may include talc particles, such as in a talc powder format. The talc powder includes talc particles from about 0.25 microns to about 100 microns, or about 0.5 microns to about 75 microns, or about 0.75 microns to about 0.5 microns, or about 1  
5 microns to about 40 microns, or about 5 microns to about 30 microns, or about 10 microns to about 25 microns, or about 15 microns to about 20 microns.

The system 100 includes the mixer 110, which can be any mixer capable of mixing liquid PET and talc in batch or continuous formats, such as a single screw mixer, double-screw mixer, continuous kneader (e.g., B&P Littleford continuous kneader; Buss Kneeder),  
10 reciprocating screw mixer (e.g., B&P Littleford TriVolution), twin-screw extruder (B&P Littleford), continuous plow mixer (e.g., B&P Littleford). In one aspect, the mixer 110 also performs one or more of: degassing, homogenizing, dispersing, or heating.

The system 100 can include a PET/talc mixture storage 138. The PET/talc mixture storage can be in any format and the PET/talc may be included therein in any format.  
15 However, the PET/talc can be pelletized prior to entering the storage or formed into any other storable format (e.g., molten liquid).

The system 100 can include an analytical system 140. The analytical system 140 includes one or more analytical systems capable of various analytical processes. For example, the analytical system 140 can be configured for determining intrinsic viscosity of melted  
20 PET/talc mixture output 102. In another example, the analytical system 140 can be configured for determining flow rate of melted PET/talc mixture output 102. In another example, the analytical system 140 can be configured for determining melting point of PET/talc mixture output 102. In another example, the analytical system 140 can be configured for determining crystallization temperature of PET/talc mixture output 102. In  
25 another example, the analytical system 140 can be configured for determining a differential scanning calorimetry profile of PET/talc mixture output 102. In another example, the analytical system 140 can be configured for determining heat distortion temperature of PET/talc mixture output 102.

In accordance with the system 100 for forming the PET/talc mixture, a method can be  
30 performed for forming the PET/talc mixture. Such a method can include: providing a feed of PET 120 (PET feed); providing a feed of talc 122 (talc feed); mixing the feed of PET with the feed of Talc in a mixer 110 at a PET:talc ratio of about 3:1 to about 1:3 to form a PET/talc mixture; and providing the PET/talc mixture as output 102. In one

aspect, the PET feed 120 is from a PET supply 124. In one aspect, the talc feed 122 is from a talc supply 126.

In one embodiment, the PET supply 124 receives the PET feed from one or more of: a PET reactor system 128; a PET recycling system 130; a PET conditioning system 132; or  
5 a PET reservoir 134. The PET reactor system 128 polymerizes the PET from PET precursor reagents. The PET recycling system 130 recycles the PET from PET articles. The PET conditioning system 132 conditions the PET for mixing with talc, the conditioning selected from one or more of heating, chopping PET pellets or sheets or other PET member, agitating, extruding, drying; off-gassing. The PET reservoir 134 of  
10 liquid PET, wherein the liquid PET is melted PET.

In one embodiment, the talc supply 126 includes talc powder in a flowable format. This can include providing the talc as powder, which can include talc particles from about 0.25 microns to about 100 microns, or about 0.5 microns to about 75 microns, or about 0.75 microns to about 0.5 microns, or about 1 microns to about 40 microns, or about 5 microns  
15 to about 30 microns, or about 10 microns to about 25 microns, or about 15 microns to about 20 microns.

In one embodiment, the method can include preparing the talc to have the talc particles, the preparing including mining, crushing, grinding, or other processing to form the talc particles. Optionally, the system 100 may include equipment for preparing the talc, such  
20 as mining equipment, crushers, grinders, or the like.

The mixing can be performed by the mixer 110, which can be any mixer capable of mixing liquid PET and talc in batch or continuous formats, such as a single screw mixer, double-screw mixer, continuous kneader (e.g., B&P Littleford continuous kneader; Buss Kneeder), reciprocating screw mixer (e.g., B&P Littleford TriVolution), twin-screw  
25 extruder (B&P Littleford), or continuous plow mixer (e.g., B&P Littleford), or other mixer that is capable of mixing the PET and talc. Optionally, the mixer 110 also performs one or more of: degassing, homogenizing, dispersing, or heating.

The method can also include providing the PET/talc mixture output 102 to an output system 136. The output system 136 provides the PET/talc mixture to storage 138 (e.g., in  
30 pellets) or a PET alloy system 200 or an analytical system 140. The method may include pelletizing the PET/talc mixture output 102 with a pelletizer. The analytical system 140 includes one or more analytical systems capable of: determining intrinsic viscosity of melted PET/talc mixture output 102; determining flow rate of melted PET/talc mixture

output 102; determining melting point of PET/talc mixture output 102; determining crystallization temperature of PET/talc mixture output 102; determining a differential scanning calorimetry profile of PET/talc mixture output 102; or determining heat distortion temperature of PET/talc mixture output 102.

5 The PET alloy system 200 is described in detail below. However, in one aspect, the PET alloy system 200 is configured to combine the PET/talc mixture output 102 with a second feed of PET 220 (second PET feed) to produce a PET alloy 202.

In one aspect, the PET feed 120 is devoid of another polymer. In another aspect, the talc feed 122 is devoid of another polymer. However, the PET feed 120 and/or talc feed may include other polymers, such as a PAT as defined herein or a polycarbonate. In one  
10 aspect, the PET feed 120 consists essentially (or consists of) of PET. In one aspect, the talc feed 122 consists essentially (or consists of) talc (optionally with trace water). In one aspect, the PET feed 120 includes melted PET.

In one embodiment, the PET feed 120 includes water at an amount less than 5%, or less  
15 than 1%, or less than 0.1%, or a trace amount of water or is devoid of water. Accordingly, the method can include drying the PET feed 120 before mixing with the talc feed 122. Also, the method can include drying the talc feed 122 before mixing with the PET feed 120.

In one embodiment, the method can include preparing the PET. As such, the method may  
20 include polymerizing the PET from polymerizable reagents.

The method can include providing PET/talc mixture output 102 having a PET:talc ratio of about 2:1 to about 1:2 or about 1:1. Alternatively, the provided PET/talc mixture output 102 has a PET concentration of about 20% to about 80%, about 25% to about 75%, about  
25 40% to about 60%, or about 50%. In another alternative, the provided PET/talc mixture output 102 has a talc concentration of about 20% to about 80%, about 25% to about 75%, about 40% to about 60%, or about 50%.

In one embodiment, the provided PET/talc mixture output 102 has an intrinsic viscosity of from about 0.25 to about 0.7, or about 0.3 to about 0.65, or about 0.35 to about 0.6, or about 0.4 to about 0.5.

30 A method of forming a Polyethylene Terephthalate (PET) alloy having talc can be performed with the system 200 of Figure 2. A system 200 for forming a Polyethylene Terephthalate (PET) alloy talc can include a feed of PET 220 (PET feed), which can include any type of PET, such as virgin PET, recycled PET, or other source of PET (e.g.,

with or without other polymers, additives, etc.). The system 200 can also include a feed of PET/talc 222 (talc feed), which can be the PET/talc mixture output 102 obtained from the method used with the system 100 of Figure 1. The system 200 can include a mixer 210 coupled to an outlet of the PET feed 220 and coupled to an outlet of the PET/talc feed 222, wherein the mixer 210 is capable of mixing PET with PET/talc to form a PET alloy having from about 1% (w/w) talc to about 50% talc (w/w). The system 200 can include an output 136 operably coupled to an outlet of the mixer 110, wherein the output is selected from a container, pump, flow line, heater, cooler, extruder, die, pelletizer, and combinations thereof.

10 In one embodiment, the system 200 can include the PET feed 220 having an inlet coupled to a PET supply 224. The PET supply 224 can be of the same type as the PET supply 124 of the system 100 of Figure 1. The system 200 can include a PET reactor system 128 that that is configured for polymerizing the PET from PET precursor reagents. The system 200 can include a PET recycling system 130 that is configured for recycling the PET from PET articles. The system 200 can include a PET conditioning system 132 that is  
15 configured for conditioning the PET for mixing with PET/talc, the conditioning selected from one or more of heating, chopping PET pellets or sheets or other PET member, agitating, extruding, drying, off-gassing, or other conditioning. The system 200 can include a PET reservoir 134 of solid PET pellets or liquid PET, wherein the liquid PET is melted PET. A heating system may also be included to heat the PET to the appropriate  
20 temperature and to liquefy the solid PET pellets, where such a heating system can be included in any system component or flow line.

In one embodiment, the system 200 can include the PET/talc feed 122 having an inlet coupled to a PET/talc supply 226. The PET/talc supply 226 can include the PET/talc mixture output 202, and may be a solid pellet form or a molten liquid form. In one aspect,  
25 the PET/talc supply 226 includes the PET/talc in a flowable format and/or includes a heater to heat the PET/talc into a flowable format (e.g., molten PET/talc liquid). In one aspect, the PET/talc includes talc particles from about 0.25 microns to about 100 microns, or about 0.5 microns to about 75 microns, or about 0.75 microns to about 0.5 microns, or  
30 about 1 microns to about 40 microns, or about 5 microns to about 30 microns, or about 10 microns to about 25 microns, or about 15 microns to about 20 microns.

In one embodiment, the mixer 210 is any mixer capable of mixing liquid PET and PET/talc in batch or continuous formats, such as a single screw mixer, double-screw

mixer, continuous kneader (e.g., B&P Littleford continuous kneader; Buss Kneeder), reciprocating screw mixer (e.g., B&P Littleford TriVolution), twin-screw extruder (B&P Littleford), continuous plow mixer (e.g., B&P Littleford), or other. The mixer 210 is configured to perform one or more of: degassing, homogenizing, dispersing, or heating.

5 In one embodiment, the system 200 can include storage 238. The storage 238 may include the PET alloy in any format, such a heated liquid or a solid (e.g., pelletized solid). The system 200 can include an analytical system 240. The analytical system 240 includes one or more analytical systems capable of various analytical processes. For example, the analytical system 240 can be configured for determining intrinsic viscosity of melted PET  
10 alloy output 202. In another example, the analytical system 240 can be configured for determining flow rate of melted PET alloy output 202. In another example, the analytical system 240 can be configure for determining melting point of PET alloy output 202. In another example, the analytical system 240 can be configured for determining crystallization temperature of PET alloy output 202. In another example, the analytical  
15 system 240 can be configured for determining a differential scanning calorimetry profile of PET alloy output 202. In another example, the analytical system 240 can be configure for determining heat distortion temperature of PET alloy output 202.

In one embodiment, the system 200 can include a manufacturing system 300 that is configured to convert the PET alloy output 202 into an article of manufacture 302. The  
20 manufacturing system 300 can include an optional component input feed 320. The optional component input feed 320 can be configured to provide an optional component to the PET alloy. The optional component can be selected from a filler, TiO<sub>2</sub>, second polymer, glass pellets, glass fibers, glass particles, sodium ionomers, sodium stearate, nucleating agent, polycarbonate, polybutylene terephthalate (PBT) or other polyalkylene  
25 terephthalate (PAT), or other component of a PET article of manufacture 302. As shown in Figure 3, the manufacturing system 300 can include one or more of: a PET alloy feed 301; one or more flow channels 308 containing flowable PET alloy; a mixer 310; a heating system 312; an extruder system 316 that produces PET alloy extrudate 317; a pumping system 318 an injection molding system 322; and/or a cooling system 314.

30 In one aspect, the optional component can be provided into the mixer 110 to be mixed into the PET/talc mixture output 102, or provided into the mixer 210 to be mixed into the PET alloy output 202. Alternatively, the provided PET 220 may include the optional component or the provided PET/talc 222 may be prepared to include the optional

component. Thus, the optional component can be introduced into the PET at any stage in the processing described herein.

The system 200 can have various modifications, such as those described herein. In one aspect, the PET feed 220 is devoid of another polymer. In one aspect, the PET/talc feed 222 is devoid of another polymer. In one aspect, the PET feed 220 consists essentially (or consists of) of PET. In one aspect, the PET/talc feed 222 consists essentially (or consists of) PET and talc (optionally with trace water). In one aspect, the PET feed 220 includes melted PET. In one aspect, the PET feed 220 includes water at an amount less than 5%, or less than 1%, or less than 0.1%, or a trace amount of water or is devoid of water.

10 In one embodiment, the system 200 can include a dryer for drying the PET feed 220 before mixing with the PET/talc feed 222. In one embodiment, the system 200 can include a dryer for drying the PET/talc feed 222 before mixing with the PET feed 220. Such a dryer can be included in any location in the system 200 or any suitable component may be outfitted with a dryer. The dryer can facilitate water removal in order to enhance processing and preparation of the PET alloy having talc.

15 In one embodiment, the system 200 can include the provided PET/talc feed 222 having a PET:talc ratio of about 3:1 to about 1:3, or about 2:1 to about 1:2 or about 1:1. In one aspect, the provided PET alloy output 202 has a PET concentration of about 50% to about 99%, about 25% to about 75%, about 40% to about 60%, or about 50%. In one aspect, the provided PET alloy output 202 has a talc concentration of about 2% to about 40%, about 5% to about 30%, about 10% to about 25%, or about 20%.

20 In one embodiment, the provided PET feed 220 of the system 200 has an intrinsic viscosity of 0.55 or more, such as from about 0.6 to about 0.9, or about 0.625 to about 0.8, or about 0.65 to about 0.7. In one aspect, the provided PET alloy output 102 has an intrinsic viscosity of from about 0.5 to about 0.9, or about 0.6 to about 0.8, or about 0.625 to about 0.7, or about 0.65 to about 0.675.

25 In one embodiment, a method of forming a Polyethylene Terephthalate (PET) alloy having talc can be performed with the system 200 as described herein. The method of forming the PET alloy having talc can include: providing a feed of PET 220 (PET feed); providing a feed of PET/talc 222 (PET/talc feed); mixing the feed of PET 220 with the feed of PET/talc 222 in a mixer 210 to form a PET alloy having from about 1% (w/w) talc to about 50% talc (w/w); and providing the PET alloy as output 202. In one aspect, the

30

PET feed 220 is from a PET supply 224, such as described herein. In one aspect, the PET/talc feed 122 is from a PET/talc supply 226, such as described herein.

In one embodiment, the method can include the PET supply 224 receiving the PET feed from one or more of: a PET reactor system 128; a PET recycling system 130; a PET conditioning system 132; or a PET reservoir 134. The PET reactor system 128 can polymerize the PET from PET precursor reagents. The PET recycling system 130 can recycle the PET from PET articles. The PET conditioning system 132 can condition the PET for mixing with PET/talc, the conditioning selected from one or more of heating, chopping PET pellets or sheets or other PET member, agitating, extruding, drying; off-gassing. The PET reservoir 134 can retain the PET in a solid state (e.g., pellets) or as liquid PET, wherein the liquid PET is melted PET.

In one embodiment, the method can include obtaining talc. The talc can be obtained as particles or formed into particles by milling. The talc particles can be from about 0.25 microns to about 100 microns, or about 0.5 microns to about 75 microns, or about 0.75 microns to about 0.5 microns, or about 1 microns to about 40 microns, or about 5 microns to about 30 microns, or about 10 microns to about 25 microns, or about 15 microns to about 20 microns.

In one embodiment, the method includes the mixer 210 mixing the PET and talc into the PET alloy having talc. Such mixing can be by any mixer capable of mixing liquid PET and talc in batch or continuous formats, such as a single screw mixer, double-screw mixer, continuous kneader (e.g., B&P Littleford continuous kneader; Buss Kneeder), reciprocating screw mixer (e.g., B&P Littleford TriVolution), twin-screw extruder (B&P Littleford), continuous plow mixer (e.g., B&P Littleford), or the like. In one aspect, the mixer 210 also performs one or more of: degassing, homogenizing, dispersing, or heating.

In one embodiment, the PET alloy output 202 is provided to an output system 236. The output system 236 provides the PET alloy to storage 238 or an analytical system 240 or a manufacturing system 300. The storage 238 may be adapted to retain the PET alloy as a liquid, such as by including heaters, or as pellets, whereby the output system 236 may include a pelletizer to pelletize the PET alloy. In one aspect, the analytical system 240 includes one or more analytical systems capable of performing one or more of the following analytical methods on the PET alloy: determining intrinsic viscosity of melted PET alloy output 202; determining flow rate of melted PET alloy output 202; determining melting point of PET alloy output 202; determining crystallization temperature of PET

alloy output 202; determining a differential scanning calorimetry profile of PET alloy output 202; or determining heat distortion temperature of PET alloy output 202. In one aspect, the manufacturing system 300 is operated to convert the PET alloy output 202 into an article of manufacture. In one aspect, the article of manufacture can be a PET alloy pellet. In one aspect, the article of manufacture can include other components, which can be introduced into the PET alloy in the system 300 or other system as described herein. The manufacturing system 300 is described in more detail herein.

In one embodiment, the method includes providing the PET feed 220 that is devoid of another polymer. In one aspect, the method can include providing the PET/talc feed 222 that is devoid of another polymer. In one aspect, the method can include providing the PET feed 220 that consists essentially (or consists of) of PET. In another aspect, the method can include providing the PET/talc feed 222 that consists essentially (or consists of) PET and talc (optionally with trace water). In one aspect, the method includes providing the PET feed 220 as melted PET. In one aspect, the method includes providing the PET feed 220 that includes water at an amount less than 5%, or less than 1%, or less than 0.1%, or a trace amount of water or is devoid of water.

In one embodiment, the method can include drying the PET feed 220 before mixing with the PET/talc feed 222. In one aspect, the method can include drying the PET/talc feed 222 before mixing with the PET feed 220.

In one embodiment, the method can include polymerizing the PET from polymerizable reagents.

In one embodiment, the method can include providing the PET/talc feed 222 with a PET:talc ratio of about 3:1 to about 1:3, or about 2:1 to about 1:2 or about 1:1. In one aspect, the method can include providing the PET alloy output 202 with a PET concentration of about 60% to about 99%, about 70% to about 95%, about 75% to about 90%, or about 80%. In one aspect, the method can include providing the PET alloy output 202 with a talc concentration of about 1% to about 40%, about 5% to about 30%, about 10% to about 25%, or about 20%.

In one embodiment, the method can include providing the PET feed 220 with an intrinsic viscosity of 0.55 or more, such as from about 0.6 to about 0.9, or about 0.625 to about 0.8, or about 0.65 to about 0.7. In one aspect, the method can include forming the PET alloy output 102 with an intrinsic viscosity of from about 0.5 to about 0.9, or about 0.6 to about 0.8, or about 0.625 to about 0.7, or about 0.65 to about 0.675.



In one embodiment, the system 200 can include a manufacturing system 300 that is configured to convert the PET alloy output 202 into an article of manufacture 302. The manufacturing system 300 can include an optional component input feed 320. The optional component input feed 320 can be configured to provide an optional component to the PET alloy. The optional component can be selected from a filler, TiO<sub>2</sub>, second polymer, glass pellets, glass fibers, glass particles, sodium ionomers, sodium stearate, nucleating agent, polycarbonate, polybutylene terephthalate (PBT) or other polyalkylene terephthalate (PAT), or other component of a PET article of manufacture 302.

As shown in Figure 3, the manufacturing system 300 can include one or more of: a PET alloy feed 301; one or more flow channels 308 containing flowable PET alloy; a mixer 310; a heating system 312 capable of heating any component of the system 300; an extruder system 316 that produces PET alloy extrudate 317 (e.g., which may also include a pelletizer to pelletize the PET alloy extrudate 317; a pumping system 318 that can pump the PET alloy to any component in the system 300; an injection molding system 322; and/or a cooling system 314 that can cool any component in the system.

As described herein, the systems 100 and corresponding method can prepare a polyethylene terephthalate/talc (PET/talc) mixture that includes PET and talc. The PET/talc can have various amounts of the talc in the PET. As such, the PET:talc can have a suitable ratio for using the PET/talc to form the PET alloy having talc. The PET/talc can include a PET:talc ratio of about 3:1 to about 1:3; however, other ratios are possible.

The PET/talc can include talc particles. The talc particles can from about 0.25 microns to about 100 microns, or about 0.5 microns to about 75 microns, or about 0.75 microns to about 0.5 microns, or about 1 microns to about 40 microns, or about 5 microns to about 30 microns, or about 10 microns to about 25 microns, or about 15 microns to about 20 microns. In one aspect, the PET/talc mixture has a PET:talc ratio of about 2:1 to about 1:2 or about 1:1. In one aspect, the PET/talc mixture has a PET concentration of about 20% to about 80%, about 25% to about 75%, about 40% to about 60%, or about 50%. In one aspect, the PET/talc mixture has a talc concentration of about 20% to about 80%, about 25% to about 75%, about 40% to about 60%, or about 50%.

In one embodiment, the PET/talc mixture includes water at an amount less than 5%, or less than 1%, or less than 0.1%, or a trace amount of water or is devoid of water. Accordingly, the PET and/or talc feeds that form the PET/talc can be devoid of water or include significantly small amounts of water.

In one aspect, the PET/talc mixture has an intrinsic viscosity of from about 0.25 to about 0.7, or about 0.3 to about 0.65, or about 0.35 to about 0.6, or about 0.4 to about 0.5.

As described herein, the systems 200 and corresponding method can prepare a polyethylene terephthalate alloy having talc. The PET alloy can have various amounts of the talc in the PET. As such, the PET:talc can have a suitable ratio PET alloy to form various articles of manufacture, such as injection molding. Such a PET alloy can include PET and talc. The PET of the PET alloy includes: a first portion of PET polymers having a first average molecular weight; and a second portion of PET polymers having a second average molecular weight. The first average molecular weight is less than the second average molecular weight. The talc is present in the PET in an amount of at least 1% and less than 50%.

High molecular weight PET chains give good strength but poor flow. Normally, there is a trade-off whereby anything done to improve flow sacrifices strength. This PET alloy provides good flow and good strength. The PET alloy can be considered to be bimodal PET, which is shown in Figure 5C. Figure 5A shows an average molecular weight distribution of normal PET, where lower weights having good flow but bad strength and higher weights have good strength but bad flow. Figure 5B shows a lower average molecular weight distribution that has more PET polymer having good flow and bad strength. In Figure 5B the PET polymer chains have been shortened, such as by hydrolysis from the talc or water in the talc, to give good flow, but the PET has poor strength because the shorter chains are not long enough to entangle effectively. Figure 5C shows the PET alloy having a portion with good flow but bad strength and a portion that is normal PET, where the lower molecular weight portion contributes to good flow of the alloy without significantly reducing strength. By producing the low molecular weight, high flow PET/talc mixture, and then combining a small fraction of the PET/talc mixture with virgin, high molecular weight PET, it was surprisingly found that the resulting PET alloy material having has very good flow while retaining excellent strength. The diagrams of Figures 5A-5C are for illustrative purposes only.

In one embodiment, a majority of the talc is associated with the PET polymers of the first portion of PET polymers. It has been found that the talc can reduce the molecular weight of PET, and thereby the PET in the PET/talc can have a smaller molecular weight than the PET that is used to form the PET/talc and/or used to form the PET alloy. The PET in the PET/talc can have the molecular weight of the first average molecular weight. The PET

supplied to the system 100 or the system 200 can have the second average molecular weight.

In one embodiment, the PET alloy includes the talc that is inhomogeneously distributed throughout the PET. In some instance, the PET alloy can be prepared without thoroughly  
5 mixing the PET and PET/talc together such that some portion have more PET/talc than others. This may be helpful in facilitating processing of the PET alloy, such as in injection molding. Alternatively, the PET alloy includes the talc that is homogeneously distributed throughout the PET. It may be worthwhile to homogeneously mix the talc throughout the PET for some products where consistency and composition is important.

10 In one embodiment, the PET alloy includes talc particles from about 0.25 microns to about 100 microns, or about 0.5 microns to about 75 microns, or about 0.75 microns to about 0.5 microns, or about 1 microns to about 40 microns, or about 5 microns to about 30 microns, or about 10 microns to about 25 microns, or about 15 microns to about 20 microns.

15 In one embodiment, the PET alloy includes water at an amount less than 5%, or less than 1%, or less than 0.1%, or a trace amount of water or is devoid of water.

In one embodiment, the PET alloy has a PET concentration of about 60% to about 99%, about 70% to about 95%, about 75% to about 90%, or about 80%.

20 In one embodiment, the PET alloy has a talc concentration of about 1% to about 40%, about 5% to about 30%, about 10% to about 25%, or about 20%.

In one embodiment, the PET alloy has an intrinsic viscosity of from about 0.5 to about 0.9, or about 0.6 to about 0.8, or about 0.625 to about 0.7, or about 0.65 to about 0.675.

The PET alloy may include an optional component. The optional component can be selected from a filler, TiO<sub>2</sub>, second polymer, glass pellets, glass fibers, glass particles,  
25 sodium ionomers, sodium stearate, nucleating agent, polycarbonate, polybutylene terephthalate (PBT) or other polyalkylene terephthalate (PAT), or other component of a PET article of manufacture 302. In one aspect, the PET alloy includes TiO<sub>2</sub>.

In one embodiment, the PET alloy has a combination of talc and TiO<sub>2</sub> particles at a combined concentration of about 1% to about 40%, about 5% to about 30%, about 10% to  
30 about 25%, or about 20%. In one embodiment, the PET alloy has TiO<sub>2</sub> particles at a concentration of about 1% to about 40%, about 5% to about 30%, about 10% to about 25%, or about 20%. In one embodiment, the PET alloy has an optional component at a

concentration of about 1% to about 40%, about 5% to about 30%, about 10% to about 25%, or about 20%.

In one embodiment, the PET alloy has a melting temperature between about 240 °C to about 250 °C, or about 245 °C.

- 5 In one embodiment, the PET alloy has an oxygen permeation rate of about 3-6 CC/(m<sup>2</sup>-day), +/- 25%, 20%, 15%, 10%, 5%, 2%, or 1%. In one aspect, the PET alloy has about 10% (w/w) talc such that the PET alloy has an oxygen permeation rate of about 3.6 CC/(m<sup>2</sup>-day), +/- 25%, 20%, 15%, 10%, 5%, 2%, or 1%. In one aspect, the PET alloy has about 20% (w/w) talc such that the PET alloy has an oxygen permeation rate of about  
10 5.6 CC/(m<sup>2</sup>-day), +/- 25%, 20%, 15%, 10%, 5%, 2%, or 1%.

In one embodiment, the PET alloy has a crystallization temperature between about 200 °C to about 230 °C, or about 210 °C to about 220 °C, or about 212 °C.

- In one embodiment, the PET alloy can be used for injection molding to form articles of manufacture. As such, an injection molding system 400 may include a feed of PET alloy  
15 420, such as shown in Figure 4, in order to form an injection molded article of manufacture 402 that includes the PET alloy. The PET alloy feed 420 may be liquid PET alloy (e.g., melted PET alloy). However, the injection molding system 400 may include a PET alloy heater 424 that heats the PET alloy feed 420 for flowability as a liquid PET alloy. The heater 424 may receive PET alloy as a pellet 428, heated liquid PET alloy 430,  
20 or as PET 432 along with PET/talc 434 which is mixed in the heater 424 that is configured as a mixer, such as a mixer described herein. The heater 424 can provide the PET alloy feed 420 to an extruder 410. Optionally, a dried and/or filtered PET alloy pellet feed 422 may be provided to the extruder 410 from a PET alloy drying and/or filtering device 426.

- 25 The PET alloy can be processed in the injection molding system 400 and through an inline filtration system in the injection molding system. The PET alloy pellets can be fed into the system 400 through a drying hopper, which in turn feeds an inlet end of a plasticizing screw of the extruder 410. The plasticizing extruding screw is encapsulated in a barrel which is heated by barrel heaters (i.e., the extruder 410). Helical (or other) flights  
30 of the screw convey the PET alloy along an operational axis of the screw. Typically, a root diameter of the screw is progressively increased along the operational axis of the screw in a direction away from the inlet end. Once a desired amount of the PET alloy melt is accumulated in the extruder, 410 it is transferred into a melt accumulator 440,

wherein the melt accumulator 440 can be equipped with an injection plunger, which performs the injection function of the melted PET alloy into a mold cavity 438.

A melt filter 436 located in fluid communication with and between the extruder 410 and the melt accumulator 440 performs the inline filtration of step. The purpose of the melt  
5 filter 436 is to filter impurities and other foreign matters from the PET alloy material being transferred from the extruder 410 to the melt accumulator 440. The specific implementation for the melt filter is not specifically limited and, as an example, an off-the-shelf filter from Gneuss Inc. of Matthews, N.C. ([www.gneuss.com](http://www.gneuss.com)) can be used to implement the melt filter 436.

10 The inline filtration step may be performed in the melt filter 436 having an inlet for allowing an inflow of the PET alloy to be filtered, and a filter outlet to allow for an outflow of the filtered PET alloy. The melt filter 436 includes a filtering member disposed between the filter inlet and filter outlet.

The mold 439 receives the PET alloy so as to fill the mold cavity 438. This is an advance  
15 over prior PET that is not sufficiently injected by such an injection molding system. Now, the mold cavity 438 can be completely filled with the PET alloy without air gaps that ruin an injection molded product. This allows the PET alloy to be injection molded into a molded PET article of manufacture 402.

In one embodiment, a mold system can include a mold 439 having a mold cavity 438.  
20 The PET alloy can have PET comprising a first portion of PET polymers having a first average molecular weight and a second portion of PET polymers having a second average molecular weight, wherein the first average molecular weight is less than the second average molecular weight. The PET alloy can have talc in the PET, wherein the talc is present in an amount of at least 1% and less than 50%. The PET alloy completely fills the  
25 mold cavity 438 of the mold 439.

The systems and methods described herein provide a novel PET alloy that can be used to prepare a number of PET products, and may be used in various processing techniques, such as injection molding. This allows the PET alloy to be injected into a mold to form  
30 an article having thin walls. Additionally, the PET alloy allows for injection molding because the cycle time from liquid PET alloy to solid PET alloy is significantly reduced compared to PET cycle times.

The PET alloy also has an improved heat distortion temperature compared to PET. The PET heat distortion temperature (HDT) may be above 66 °C at 0.46 MPa (i.e., 66 psi) and

thereby may range from 68 °C at 0.46 MPa to about 95 °C at 0.46 MPa, or about 70 °C at 0.46 MPa to about 90 °C at 0.46 MPa, or about 72 °C at 0.46 MPa to about 88 °C at 0.46 MPa. This allows an article of manufacture having the PET alloy to be articles that can contain or retain hot materials, such as hot liquid drinks, and thereby the PET alloy can be used to prepare hot beverage containers as an article of manufacture. Additionally, many manufacturing processes fill a container with a hot material, and then the hot material is cooled while in the container, and now the improved HDT of the PET alloy allows the PET alloy to be used as such a container in a manufacturing process to receive hot liquids therein. The PET alloy retains the shape of the container without buckling or other unfavorable distortion. In one aspect, the PET alloy has a sufficient HDT, which allows the PET alloy to form articles that are dishwasher safe. In one aspect, the PET alloy has a sufficient HDT, which allows the PET alloy to form articles that are microwave safe. The PET alloy exhibits easy snap-ability making it useful in scored end products, such as yogurt multi-packs and medical blister packs as well as related products.

While PET has been described herein, the systems and methods may also be used to prepare a Polyalkylene Terephthalate (PAT).

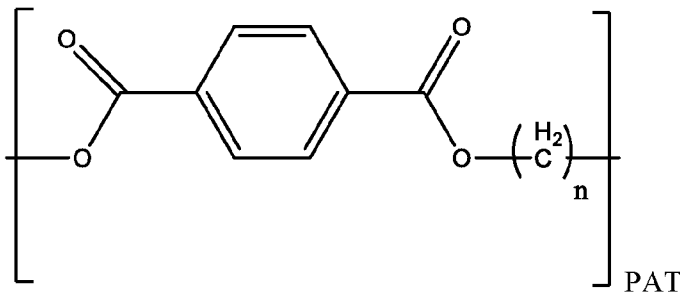

In the Polyalkylene Terephthalate (PAT) structure,  $n$  may be any reasonable integer, such as 1 (Polymethylene Terephthalate (PMT)), 2 (Polyethylene Terephthalate (PET)), 3 Polypropylene Terephthalate (PPT), 4 (Polybutylene Terephthalate (PBT)), or 5 Polypropylene Terephthalate (PPentT), or the like (e.g.,  $n$  is 6, 7, 8, 9, 10, etc.). As such, the methods and systems described herein can be adapted for use with any suitable polyalkylene. That is the PET in the PET/talc may be substituted with any PAT so as to form PAT/talc. The PET in the PET alloy may be substituted with any PAT so as to form the PAT alloy. In some instances, the PAT/talc may include a first PAT (e.g., PET), and the virgin PAT mixed with the PAT/talc may include a second different PAT (e.g., PBT), such that the PAT alloy has two different PATs with the talc.

Accordingly, while the systems and methods described herein are directed to PET, such systems and methods may include any reasonable PAT, such as PBT.

#### EXPERIMENTAL

The PET alloy was prepared by first preparing the PET/talc mixture, and then preparing the PET alloy. A comparison was performed between PET (e.g., no talc), PET/talc having 50% by weight PET and 50% by weight talc, PET/talc having 80% PET and 20% talc by weight, and the PET alloy having 80% PET and 20% talc by weight. The parameters are shown in Table 1.

Table 1

	<b>%PET/%Talc</b>	<b>IV</b>	<b>% Crystallinity</b>
PET	100/0	0.684	39.7
PET/talc	50/50	0.361	27.92
PET/talc 2	80/20	0.482	13
PET Alloy	80/20	0.664	34.4

10

Table 1 shows that the IV (Intrinsic Viscosity), which indicates of the size of the molecules within the polymer for: PET; PET/talc with 50% (by weight) talc in the undried PET; PET/talc 2, which is the polymer with 20% talc directly added to the PET without intermediate steps to produce the alloy; and PET alloy. As can be seen by the numbers, the PET alloy has lower crystallinity and a lower IV. The direct addition example has too low of an IV to be useful in the end products produced by injection molding. Thus, the PET alloy provides a significant benefit.

15

A comparison study was conducted to test the flow differences between the PET alloy having talc versus PET without any talc. The fork tested was a 0.023" thickness fork, and the fork mold was tested on a 250 MT Krauss Maffei injection molding machine. The PET alloy filled the mold, but PET did not fill the mold even when attempting to maximizing the pressure and increasing cycle time. Thus, now PET alloy can be used in injection molding because it can fill the mold space without unfavorable air gaps.

20

PET alloy was prepared and tested using differential scanning calorimetry (DSC) in accordance with standard procedures. The following were tested: PET; talc filled PET sheet; thermoformed PET alloy at 110 °C (110 PET alloy); thermoformed PET alloy at 120 °C (120 PET alloy); thermoformed PET alloy at 125 °C (125 PET alloy); and thermoformed PET alloy at 105 °C (105 PET alloy). Figure 6A shows an overlay of the

25

DSC thermograms for PET. Figure 6B shows an overlay of the DSC thermograms for talc filled PET sheet. Figure 6C shows an overlay of the DSC thermograms for 110 PET alloy. Figure 6D shows an overlay of the DSC thermograms for 120 PET alloy. Figure 6E shows an overlay of the DSC thermograms for 125 PET alloy. 6F shows an overlay of the DSC thermograms for 125 PET alloy. The data provided the following information shown in Figure 7. Additionally, the following percent crystallinity was determined: PET 5.3%; talc filled PET sheet 13.5%; thermoformed PET alloy at 110 °C (110 PET alloy) 25.8%; thermoformed PET alloy at 120 °C (120 PET alloy) 27.2%; thermoformed PET alloy at 125 °C (125 PET alloy) 29.5%; and thermoformed PET alloy at 105 °C (105 PET alloy) 23.8%. The PET alloy included 16% talc. As such, higher or lower amounts of talc can adjust the values toward the PET values when less talc and further away from the PET values with more talc.

It was found that the presence of talc filler generally reduced the thermal transition temperatures. In the first heating cycles, the melting temperature of the unfilled PET Sheet (PET only) was about 252 °C while the other samples melted between 245 °C and 247 °C. Other transitions in both heating cycles were similarly affected. The crystallinity was observed to be dependent on the processing temperature. The samples exhibited increasing crystallinity with increased temperature. The increased crystallinity proves that the talc is nucleating the PET crystallization. Increased crystallinity is well-known to improve yield strength and barrier properties (crystal are impermeable). Most importantly, to get high HDT the PET needs significant crystallinity plus a reinforcing filler such as talc, which is achieved with the PET alloy having talc.

Figure 8 shows the gas permeability data for PET (control), PET alloy with 10% talc (VF2), and PET alloy with 20% talc (VF4). This data shows that standard PET has an oxygen transmission rate of 8.67 CC/(m<sup>2</sup>-day), whereas the PET alloy materials have values 35% and almost 60% lower. Permeability of other gases will change by the same amounts. The reduced gas permeability can be useful for food packaging applications as it helps keep the food fresh longer, which shows the PET can be utilized in food containers.

Dilute solution viscometry was performed with PET, PET 20% talc (e.g., PET containing 20% by weight talc), and PET alloy (e.g., PET containing 50% by weight talc at 40% and PET at 60%). The sample mass of each specimen was adjusted to account for filler content as appropriate. Portions of each sample were dissolved with heating in 60/40 phenol/1,1,2,2 tetrachloroethane containing isooctyl mercaptopropionate stabilizer. The



solutions were heated for a total of 3 hours and 10 minutes. The solutions were then filtered through wire mesh and viscosities were measured in Ubbelohde 1B viscometers at 30.00°C. Inherent viscosity is reported as follows, as is intrinsic viscosity calculated using the Billmeyer Approximation. PET had inherent viscosity of 0.654 (dL/g) and 0.684  
5 intrinsic viscosity (dL/g). PET 20% talc had inherent viscosity of 0.467 (dL/g) and 0.482 intrinsic viscosity (dL/g). PET alloy had inherent viscosity of 0.636 (dL/g) and 0.664 intrinsic viscosity (dL/g). These three PET compositions were also tested with DSC, which resulted in the data in Figure 9. The crystallinity for these three PET compositions was determined as: PET 30.7%; PET 20% Talc 13.0%; and PET alloy 34.4%. The PET  
10 20% talc and PET alloy compositions underwent size exclusion chromatography, which resulted in the data of Figure 10. The refractive index (RI) chromatograms, cumulative molar mass distribution plots, and differential molar mass distribution were compared to the calibration curve to determine the molar mass averages ( $M_n$  (number average),  $M_w$  (weight average), and  $M_z$  (Z average) and polydispersity ( $M_w/M_n$ )). The data were  
15 indicative of the PET alloy having a higher molar mass than the PET 20% talc sample. The PET alloy also exhibited a larger polydispersity index, consistent with a more broad distribution. The neat PET sample, which was only tested for inherent viscosity, has a higher molar mass than the PET alloy and PET 20% talc samples. The PET 20% talc sample exhibited a melting peak at 247 °C. The neat PET sample and the PET alloy each  
20 exhibited a bimodal melting peaks with maxima around 233°C and 247°C, respectively. As-received crystallinity for the PET 20% talc sample was substantially lower at 13% as compared to crystallinity of the neat PET (40%) and the PET alloy (34%).

The molecular weights can be defined as shown in the examples. The blending of a small amount of lower molecular weight PET with a large fraction of high molecular weight  
25 PET should hold valid no matter what the molecular weights. However, for practical purposes, the mechanical properties, in particular strength will be too low if the higher molecular weight component has an insufficient molecular weight for entanglements to form. For example, the higher molecular weight fraction (e.g., virgin PET, or PAT) should have an IV over 0.55.

30 Additionally, the HDT was tested for PET and PET alloy having talc over a range of weight percent of talc, which is shown in Figure 11. Accordingly, the HDT increased as the amount of talc increased, which shows that the PET alloy can be used for products with higher temperatures of use than PET. Figure 12 shows that adding a glass fiber

further increases the HDT, increases the flexural modulus (Kpsi), and flexural strength (psi).

Additionally, the PET alloy (Figure 13A) was compared to general purpose polystyrene (GPPS) (Figure 13B) to study mechanical properties. The PET alloy show better  
5 mechanical properties than GPPS, and the PET alloy can be prepared at comparable costs. Thus, the PET alloy prepared by the systems and methods described herein from the PET and PET/talc two-stage preparation can be a useful plastic for preparing a number of articles of manufacture in a wide range of manufacturing techniques. Now, the PET alloy can be used in injection molding to prepare thin walled molded articles.

10 The PET/talc was prepared as described herein for use in the experiments. An example of such a process is provided. The PET feed at 60% and talc feed at 40% were provided to extruder having a barrel temperature between about 517 °F and 565 °F (e.g., over 500 °F) and mixed as the mixture pushed through the extruder. The head pressure was about 370 psi, suction pressure of 293 psi, discharge pressure of 424 psi, and melt pressure of 266  
15 psi. The extruder was operated at 145.5 RPM, with a torque of 49.7, a gear pump having 17 RPM with a torque of 7.1. There were various die zones having the temperature at about 530 °F. Throughput was about 1098 lbs/hour. The intrinsic viscosity was about 0.656. Various percentages of PET and talc can be prepared with similar operating parameters.

20 Additionally, the PET/talc was mixed with virgin PET using similar operating parameters, with some variations, to prepare the PET alloy. These parameters values for preparing the PET/talc or PET alloy may vary by +/- 1, 2, 3, 5, 10, 15, 20, 25, 30 or 50%. The PET alloy was used successfully for injection molding, where the PET alloy filled the mold. While a single cavity hot runner was used as an example, multiple cavities have  
25 also been successfully used. The molding machine was a KM 120, with a sprue radii of 3.4" and 9.32" orifice. The barrel temperature was 470 °F, 465 °F, 460 °F, 455 °F, and 445 °F along the length. The injection speed was about 2 inches/second, with a 7500 psi injection pressure setting, and holding pressure of 5000 psi. The plasticizing speed was about 200 RPM. The cooling time was about 2 seconds with an 8.67 second cycle time.  
30 The injection time was about 0.44 seconds. The mold cooling temperature was about 65 °F at the front and 90 °F at the rear. The gate was a 0.031 pin gate. This shows that the PET alloy can be used in injection molding to make a variety of injection molded

products, from utensils, food containers, hot product containers, plates, and other articles of manufacture.

For an injection molded fork, the cycle time for PP copolymer was 7.1 seconds whereas the PET alloy material described herein can be molded in 6.2 seconds. Furthermore, the  
5 PP fork was too thin and of insufficient stiffness to be useable as a fork whereas the PET alloy material gave a stiffer, useable fork. Mold temperature was changed between 100 °F and 60 °F. Valve gate was about 650 °F. Further reducing the mold temperature to just 50 °F gave a cycle time of just 5.9 seconds. Black color was added to the PET alloy material via masterbatch concentrate. The color was even and cycle times were unaffected. All  
10 trials were done over many shots and steady state conditions to assure repeatability. This trial was performed in a 120 ton Krauss Maffei injection molding machine. Other successful trials were performed in different machines with a variety of gate / runner configurations. The PET alloy fork weight averaged 2.8 g, whereas the PP fork produced in the same mold weighed 1.7 g.

15 In a separate trial, general purpose polystyrene was compared to the PET alloy material. The trial used an Ineos Styrolution 3600/3601 grade general purpose polystyrene (GPPS) commonly used for cutlery production. The molding process for GPPS was refined to an 8.67 second overall cycle time. The fork had a wall thickness of 0.023 which is adequate for the modified PET but produced a weak, brittle general purpose polystyrene fork. A  
20 0.026 diameter hot pin gate was used. The cycle time for the PET alloy material was 9.6 seconds.

Further trials were run utilizing a 1991 350 ton Krauss Maffei injection molding machine with hydraulic clamping and a twenty-four ounce barrel. A twenty-five cavity spoon mold of the so-called “hot-to-cold” type was used. The PET alloy material with 15% and 20%  
25 talc both resulted in good quality molded parts and cycle times.

For this and other processes and methods disclosed herein, the operations performed in the processes and methods may be implemented in differing order. Furthermore, the outlined operations are only provided as examples, and some operations may be optional, combined into fewer operations, eliminated, supplemented with further operations, or  
30 expanded into additional operations, without detracting from the essence of the disclosed embodiments.

## CLAIMS

1. A method of forming a polyethylene terephthalate (PET) mixture with talc, the method comprising:
- 5 providing a feed of PET (PET feed);  
providing a feed of talc (talc feed);  
mixing the feed of PET with the feed of talc in a mixer at a PET:talc ratio of about 3:1 to about 1:3 to form a PET/talc mixture; and  
providing the PET/talc mixture as output.
2. The method of claim 1, wherein:
- 10 the PET feed is from a PET supply; and/or  
the talc feed is from a talc supply having talc particles from about 0.25 microns to about 100 microns, or about 0.5 microns to about 75 microns, or about 0.75 microns to about 0.5 microns, or about 1 microns to about 40 microns, or about 5 microns to about 30 microns, or about 10 microns to about 25 microns, or about 15 microns to about 20  
15 microns.
3. The method of claim 2, wherein the PET supply receives the PET feed from one or more of:
- a PET reactor system, the PET reactor system polymerizes the PET from PET precursor reagents;
- 20 a PET recycling system, the PET recycling system recycles the PET from PET articles;
- a PET conditioning system, the PET conditioning system conditions the PET for mixing with talc, the conditioning selected from one or more of heating, chopping PET pellets or sheets or other PET member, agitating, extruding, drying; off-gassing; or
- 25 a PET reservoir, the PET reservoir of liquid PET, wherein the liquid PET is melted PET.
4. The method of claim 1, wherein the mixer is any mixer capable of mixing liquid PET and talc in batch or continuous formats, such as a single screw mixer, double-screw mixer, continuous kneader, reciprocating screw mixer, twin-screw extruder,  
30 continuous plow mixer, or combinations thereof.
5. The method of claim 1, comprising providing the PET/talc mixture output to an output system that provides the PET/talc mixture to storage or a PET alloy system

or an analytical system, wherein the analytical system includes one or more analytical systems performing:

- determining intrinsic viscosity of melted PET/talc mixture output;
- determining flow rate of melted PET/talc mixture output;
- 5 determining melting point of PET/talc mixture output;
- determining crystallization temperature of PET/talc mixture output;
- determining a differential scanning calorimetry profile of PET/talc mixture output;

or

- determining heat distortion temperature of PET/talc mixture output.

10 6. The method of claim 1, comprising combining the PET/talc mixture output with a second feed of PET (second PET feed) to produce a PET alloy.

- 7. The method of claim 1, wherein:
  - the PET feed is devoid of another polymer; and/or
  - the talc feed is devoid of another polymer.

15 8. The method of claim 1, comprising:

- drying the PET feed before mixing with the talc feed; and/or
- drying the talc feed before mixing with the PET feed.

9. The method of claim 1, comprising polymerizing the PET from polymerizable reagents.

20 10. The method of claim 1, wherein the mixing in the mixer includes mixing in anti-static agents, anti-bacterial agents, foaming agents, stabilizers, UV blockers, acetaldehyde scavengers, pigments, lubricants and other typical additives for plastics.

25 11. The method of claim 1, wherein:

- the provided PET/talc mixture output has a PET:talc ratio of about 2:1 to about 1:2 or about 1:1; or

- the provided PET/talc mixture output has a PET concentration of about 20% to about 80%, about 25% to about 75%, about 40% to about 60%, or about 50%; or

- the provided PET/talc mixture output has a talc concentration of about 20% to about 80%, about 25% to about 75%, about 40% to about 60%, or about 50%.

30 12. The method of claim 1, wherein:

- the provided PET/talc mixture output has an intrinsic viscosity of from about 0.25 to about 0.7, or about 0.3 to about 0.65, or about 0.35 to about 0.6, or about 0.4 to about 0.5.

13. A system for forming a Polyethylene Terephthalate (PET) mixture with talc in claims 1-12, the system comprising:

a feed of PET (PET feed);

a feed of talc (talc feed); and

5 a mixer coupled to an outlet of the PET feed and coupled to an outlet of the talc feed, wherein the mixer is capable of mixing PET with Talc at a PET:talc ratio of about 3:1 to about 1:3 to form a PET/talc mixture.

14. The system of claim 13, further comprising an output operably coupled to an outlet of the mixer, wherein the output is selected from a container, pump, flow line, heater, cooler, extruder, die, pelletizer, mixer, and combinations thereof.

15. The system of claim 13, further comprising one or more of:

a PET reactor system is configured to polymerize the PET from PET precursor reagents;

a PET recycling system is configured to recycle the PET from PET articles;

15 a PET conditioning system is configured to condition the PET for mixing with talc, the conditioning selected from one or more of heating, chopping PET pellets or sheets or other PET member, agitating, extruding, drying; off-gassing; or

a PET reservoir of liquid PET, wherein the liquid PET is melted PET.

16. The system of claim 13, comprising a talc supply that includes talc powder  
20 in a flowable format, wherein the talc powder includes talc particles from about 0.25 microns to about 100 microns, or about 0.5 microns to about 75 microns, or about 0.75 microns to about 0.5 microns, or about 1 microns to about 40 microns, or about 5 microns to about 30 microns, or about 10 microns to about 25 microns, or about 15 microns to about 20 microns.

25 17. The system of claim 13, wherein the mixer is any mixer capable of mixing liquid PET and talc in batch or continuous formats, such as a single screw mixer, double-screw mixer, continuous kneader, reciprocating screw mixer, twin-screw extruder, or continuous plow mixer.

30 18. The system of claim 30, wherein the mixer also performs one or more of: degassing, homogenizing, dispersing, or heating.

19. The system of claim 13, comprising an analytical system that includes one or more analytical systems capable of:

determining intrinsic viscosity of melted PET/talc mixture output;

determining flow rate of melted PET/talc mixture output;  
determining melting point of PET/talc mixture output;  
determining crystallization temperature of PET/talc mixture output;  
determining a differential scanning calorimetry profile of PET/talc mixture output;

5 or

determining heat distortion temperature of PET/talc mixture output.

20. A method of forming a Polyethylene Terephthalate (PET) alloy having talc, the method comprising:

10 providing a feed of the PET/talc mixture (PET/talc feed) of one of claims 1-12;  
providing a feed of PET (PET feed);  
mixing the feed of PET with the feed of PET/talc in a mixer to form a PET alloy having from about 1% (w/w) talc to about 50% talc (w/w); and  
providing the PET alloy as output.

21. The method of claim 20, wherein:  
15 the PET feed is from a PET supply; and/or  
the PET/talc feed is from a PET/talc supply.

22. The method of claim 21, wherein the PET supply receives the PET feed from one or more of:

20 a PET reactor system, the PET reactor system polymerizes the PET from PET precursor reagents;

a PET recycling system recycles the PET from PET articles;

a PET conditioning system conditions the PET for mixing with PET/talc, the conditioning selected from one or more of heating, chopping PET pellets or sheets or other PET member, agitating, extruding, drying; off-gassing; or

25 a PET reservoir of liquid PET, wherein the liquid PET is melted PET.

23. The method of claim 20, wherein the talc includes talc particles from about 0.25 microns to about 100 microns, or about 0.5 microns to about 75 microns, or about 0.75 microns to about 0.5 microns, or about 1 microns to about 40 microns, or about 5 microns to about 30 microns, or about 10 microns to about 25 microns, or about 15  
30 microns to about 20 microns.

24. The method of claim 20, wherein the mixer is any mixer capable of mixing liquid PET and talc in batch or continuous formats, such as a single screw mixer, double-

screw mixer, continuous kneader, reciprocating screw mixer, twin-screw extruder, continuous plow mixer, or combinations thereof.

25. The method of claim 24, wherein the mixer also performs one or more of: degassing, homogenizing, dispersing, or heating.

5 26. The method of claim 20, comprising providing the PET alloy output to an output system, wherein the output system provides the PET alloy to storage or an analytical system or a manufacturing system.

27. The method of claim 26, wherein the analytical system includes one or more analytical systems capable of:

10 determining intrinsic viscosity of melted PET alloy output;  
determining flow rate of melted PET alloy output;  
determining melting point of PET alloy output;  
determining crystallization temperature of PET alloy output;  
determining a differential scanning calorimetry profile of PET alloy output; or  
15 determining heat distortion temperature of PET alloy output.

28. The method of claim 26, wherein the manufacturing system is configured to convert the PET alloy output into an article of manufacture, the method comprising converting the PET alloy output into the article of manufacture.

29. The method of claim 20, comprising:  
20 drying the PET feed before mixing with the PET/talc feed; and/or  
drying the PET/talc feed before mixing with the PET feed.

30. The method of claim 20, wherein the mixing in the mixer includes mixing in anti-static agents, anti-bacterial agents, foaming agents, stabilizers, UV blockers, acetaldehyde scavengers, pigments, lubricants and other typical additives for plastics.

25 31. The method of claim 20, wherein:  
the provided PET/talc feed has a PET:talc ratio of about 3:1 to about 1:3, or about 2:1 to about 1:2 or about 1:1 or

the provided PET alloy output has a PET concentration of about 60% to about 99%, about 70% to about 95%, about 75% to about 90%, or about 80%; or

30 the provided PET alloy output has a talc concentration of about 1% to about 40%, about 5% to about 30%, about 10% to about 25%, or about 20%.

32. The method of claim 20, wherein:



the provided PET feed 220 has an intrinsic viscosity of at least 0.55, such as from about 0.6 to about 0.9, or about 0.625 to about 0.8, or about 0.65 to about 0.7;

the provided PET alloy output 102 has an intrinsic viscosity of from about 0.5 to about 0.9, or about 0.6 to about 0.8, or about 0.625 to about 0.7, or about 0.65 to about  
5 0.675.

33. A system for forming a Polyethylene Terephthalate (PET) alloy having talc of claim 20, the system comprising:

a feed of PET (PET feed);

a feed of PET/talc (talc feed);

10 a mixer coupled to an outlet of the PET feed and coupled to an outlet of the PET/talc feed, wherein the mixer is capable of mixing PET with PET/talc to form a PET alloy having from about 1% (w/w) talc to about 50% talc (w/w).

34. The system of claim 33, further comprising an output operably coupled to an outlet of the mixer, wherein the output is selected from a container, pump, flow line,  
15 heater, cooler, extruder, die, pelletizer, mixer, and combinations thereof.

35. The system of claim 34, wherein:

the PET feed having an inlet coupled to a PET supply; and/or

the PET/talc feed having an inlet coupled to a PET/talc supply.

36. The system of claim 35, further comprising one or more of:

20 a PET reactor system that polymerizes the PET from PET precursor reagents;

a PET recycling system that recycles the PET from PET articles;

a PET conditioning system that conditions the PET for mixing with PET/talc, the conditioning selected from one or more of heating, chopping PET pellets or sheets or other PET member, agitating, extruding, drying; off-gassing; or

25 a PET reservoir of liquid PET, wherein the liquid PET is melted PET.

37. The system 200 of claim 36, wherein the PET/talc supply includes the PET/talc in a flowable format.

38. The system 200 of claim 37, wherein the talc includes talc particles from about 0.25 microns to about 100 microns, or about 0.5 microns to about 75 microns, or  
30 about 0.75 microns to about 0.5 microns, or about 1 microns to about 40 microns, or about 5 microns to about 30 microns, or about 10 microns to about 25 microns, or about 15 microns to about 20 microns.

39. The system of claim 33, wherein the mixer is any mixer capable of mixing liquid PET and talc in batch or continuous formats, such as a single screw mixer, double-screw mixer, continuous kneader, reciprocating screw mixer, twin-screw extruder, continuous plow mixer, or combinations thereof.

5 40. The system of claim 39, wherein the mixer is configured to perform one or more of: degassing, homogenizing, dispersing, or heating.

41. The system of claim 33, comprising:

storage; and/or

an analytical system; and/or

10 a manufacturing system.

42. The system of claim 41, wherein the analytical system includes one or more analytical systems capable of:

determining intrinsic viscosity of melted PET alloy output;

determining flow rate of melted PET alloy output;

15 determining melting point of PET alloy output;

determining crystallization temperature of PET alloy output;

determining a differential scanning calorimetry profile of PET alloy output; or

determining heat distortion temperature of PET alloy output.

20 43. The system of claim 41, wherein the manufacturing system is configured to convert the PET alloy output into an article of manufacture.

44. The system of claim 43, the manufacturing system comprising:

an optional component input feed, the optional component input feed being configured to provide an optional component, the optional component being selected from a filler, TiO<sub>2</sub>, second polymer, glass pellets, glass fibers, glass particles, sodium ionomers, sodium stearate, nucleating agent, anti-static agents, anti-bacterial agents, foaming agents, stabilizers, UV blockers, acetaldehyde scavengers, pigments, lubricants and other typical additives for plastics, polycarbonate, polybutylene terephthalate (PBT) or other polyalkylene terephthalate (PAT), or other component of a PET article of manufacture.

30 45. The system of claim 44, the manufacturing system comprising one or more of:

a PET alloy feed;

one or more flow channels containing flowable PET alloy;

a mixer;  
heating system;  
an extruder system that produces PET alloy extrudate;  
pumping system;  
5 injection molding system; and/or  
cooling system.

46. The system of claim 33, wherein:

the provided PET/talc feed has a PET:talc ratio of about 3:1 to about 1:3, or about  
2:1 to about 1:2 or about 1:1 or

10 the provided PET alloy output has a PET concentration of about 50% to about  
99%, about 25% to about 75%, about 40% to about 60%, or about 50%; or

the provided PET alloy output has a talc concentration of about 2% to about 40%,  
about 5% to about 30%, about 10% to about 25%, or about 20%.

47. The system of claim 33, wherein:

15 the provided PET feed has an intrinsic viscosity of at least 0.55, such as from  
about 0.6 to about 0.9, or about 0.625 to about 0.8, or about 0.65 to about 0.7;

the provided PET alloy output has an intrinsic viscosity of from about 0.5 to about  
0.9, or about 0.6 to about 0.8, or about 0.625 to about 0.7, or about 0.65 to about 0.675.

20 48. A polyethylene terephthalate/talc (PET/talc) mixture prepared from the  
method of one of claims 1-12, the PET/talc mixture comprising:

polyethylene terephthalate (PET) containing talc at a PET:talc ratio of about 3:1 to  
about 1:3.

25 49. The PET/talc mixture of claim 48, wherein the talc includes talc particles  
from about 0.25 microns to about 100 microns, or about 0.5 microns to about 75 microns,  
or about 0.75 microns to about 0.5 microns, or about 1 microns to about 40 microns, or  
about 5 microns to about 30 microns, or about 10 microns to about 25 microns, or about  
15 microns to about 20 microns.

30 50. The PET/talc mixture of claim 49, wherein the PET/talc mixture includes  
water at an amount less than 5%, or less than 1%, or less than 0.1%, or a trace amount of  
water or is devoid of water.

51. The PET/talc mixture of claim 48, wherein the PET/talc mixture has a  
PET:talc ratio of about 2:1 to about 1:2 or about 1:1.

52. The PET/talc mixture of claim 48, wherein the PET/talc mixture has a PET concentration of about 20% to about 80%, about 25% to about 75%, about 40% to about 60%, or about 50%.

53. The PET/talc mixture of claim 48 wherein the PET/talc mixture has a talc  
5 concentration of about 20% to about 80%, about 25% to about 75%, about 40% to about 60%, or about 50%.

54. The PET/talc mixture of claim 48, wherein the PET/talc mixture has an intrinsic viscosity of from about 0.25 to about 0.7, or about 0.3 to about 0.65, or about 0.35 to about 0.6, or about 0.4 to about 0.5.

10 55. The PET/talc mixture of claim 48, wherein the PET/talc mixture better crystallization potential compared to virgin PET.

56. The PET/talc mixture of claim 48, further comprising one or more of: a filler, TiO<sub>2</sub>, second polymer, glass pellets, glass fibers, glass particles, sodium ionomers, sodium stearate, nucleating agent, anti-static agents, anti-bacterial agents, foaming agents,  
15 stabilizers, UV blockers, acetaldehyde scavengers, pigments, lubricants and other typical additives for plastics, polycarbonate, polybutylene terephthalate (PBT) or other polyalkylene terephthalate (PAT), or other component of a PET article of manufacture.

57. A polyethylene terephthalate (PET) alloy prepared from the method of claim 20 comprising:

20 PET comprising:

a first portion of PET polymers having a first average molecular weight;  
a second portion of PET polymers having a second average molecular weight,

25 wherein the first average molecular weight is less than the second average molecular weight; and

talc in the PET, wherein the talc is present in an amount of at least 1% and less than 50%.

58. The PET alloy of claim 57, wherein a majority of the talc is associated with the PET polymers of the first portion of PET polymers.

30 59. The PET alloy of claim 57, wherein the talc is inhomogeneously distributed throughout the PET.

60. The PET alloy of claim 57, wherein the talc is homogeneously distributed throughout the PET.

61. The PET alloy of claim 57, wherein the talc includes talc particles from about 0.25 microns to about 100 microns, or about 0.5 microns to about 75 microns, or about 0.75 microns to about 0.5 microns, or about 1 microns to about 40 microns, or about 5 microns to about 30 microns, or about 10 microns to about 25 microns, or about 15 microns to about 20 microns.

62. The PET alloy of claim 57, wherein the PET alloy includes water at an amount less than 5%, or less than 1%, or less than 0.1%, or a trace amount of water or is devoid of water.

63. The PET alloy of claim 57, wherein the PET alloy has a PET concentration of about 60% to about 99%, about 70% to about 95%, about 75% to about 90%, or about 80%.

64. The PET alloy of claim 57, wherein the PET alloy has a talc concentration of about 1% to about 40%, about 5% to about 30%, about 10% to about 25%, or about 20%.

65. The PET alloy of claim 57, wherein the PET alloy has an intrinsic viscosity of from about 0.5 to about 0.9, or about 0.6 to about 0.8, or about 0.625 to about 0.7, or about 0.65 to about 0.675.

66. The PET alloy of claim 57, wherein the PET alloy has better crystallization potential compared to virgin PET.

67. The PET alloy of claim 57, further comprising  $\text{TiO}_2$ .

68. The PET alloy of claim 67, wherein the PET alloy has a combination of talc and  $\text{TiO}_2$  particles at a combined concentration of about 1% to about 40%, about 5% to about 30%, about 10% to about 25%, or about 20%.

69. The PET alloy of claim 57, wherein the PET alloy has a melting temperature between about 240 °C to about 250 °C, or about 245 °C.

70. The PET alloy of claim 57, wherein the PET alloy has an oxygen permeation rate of about 3-6 CC/(m<sup>2</sup>-day), +/- 25%, 20%, 15%, 10%, 5%, 2%, or 1%.

71. The PET alloy of claim 57, wherein the PET alloy has about 10% (w/w) talc has an oxygen permeation rate of about 3.6 CC/(m<sup>2</sup>-day), +/- 25%, 20%, 15%, 10%, 5%, 2%, or 1%.

72. The PET alloy of claim 57, wherein the PET alloy has about 20% (w/w) talc has an oxygen permeation rate of about 5.6 CC/(m<sup>2</sup>-day), +/- 25%, 20%, 15%, 10%, 5%, 2%, or 1%.

73. The PET alloy of claim 57, wherein the PET alloy has a crystallization temperature between about 200 °C to about 230 °C, or about 210 °C to about 220 °C, or about 212 °C.

74. The PET alloy of claim 67, further comprising one or more of: a filler,  
5 TiO<sub>2</sub>, second polymer, glass pellets, glass fibers, glass particles, sodium ionomers, sodium stearate, nucleating agent, anti-static agents, anti-bacterial agents, foaming agents, stabilizers, UV blockers, acetaldehyde scavengers, pigments, lubricants and other typical additives for plastics polycarbonate, polybutylene terephthalate (PBT) or other polyalkylene terephthalate (PAT), or other component of a PET article of manufacture.

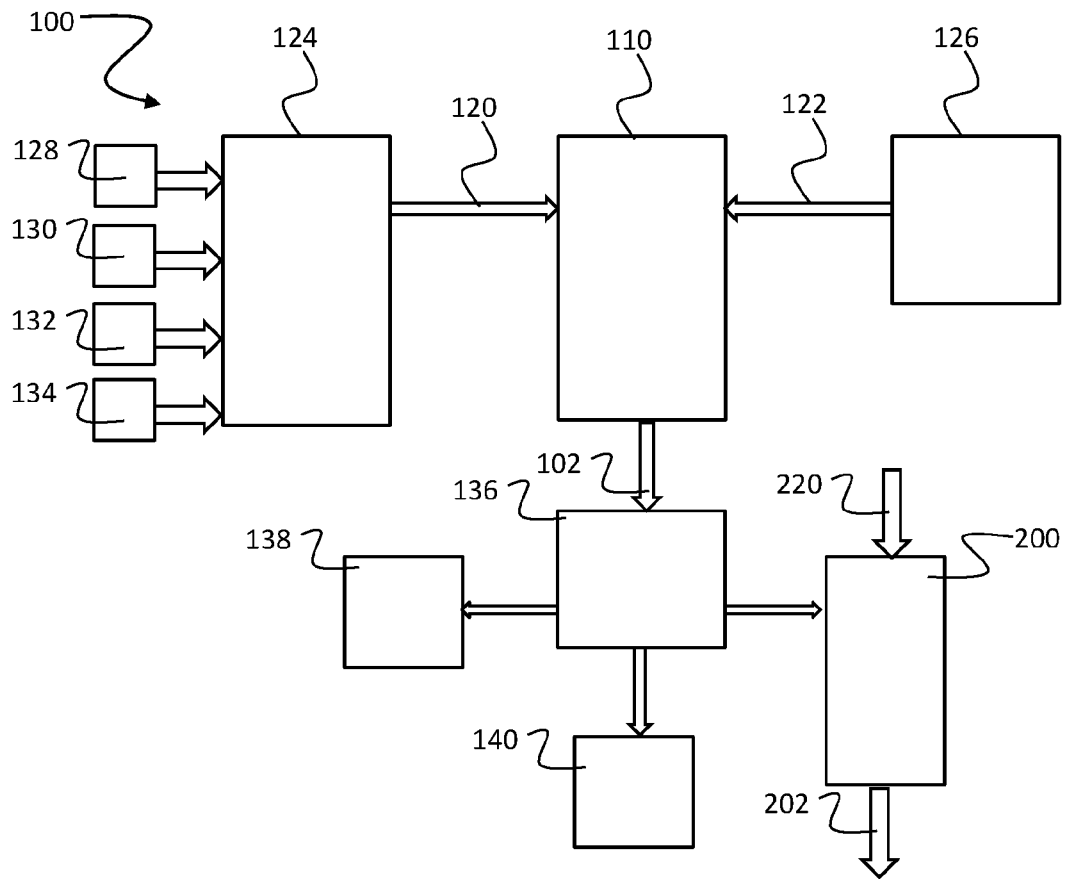

Fig. 1

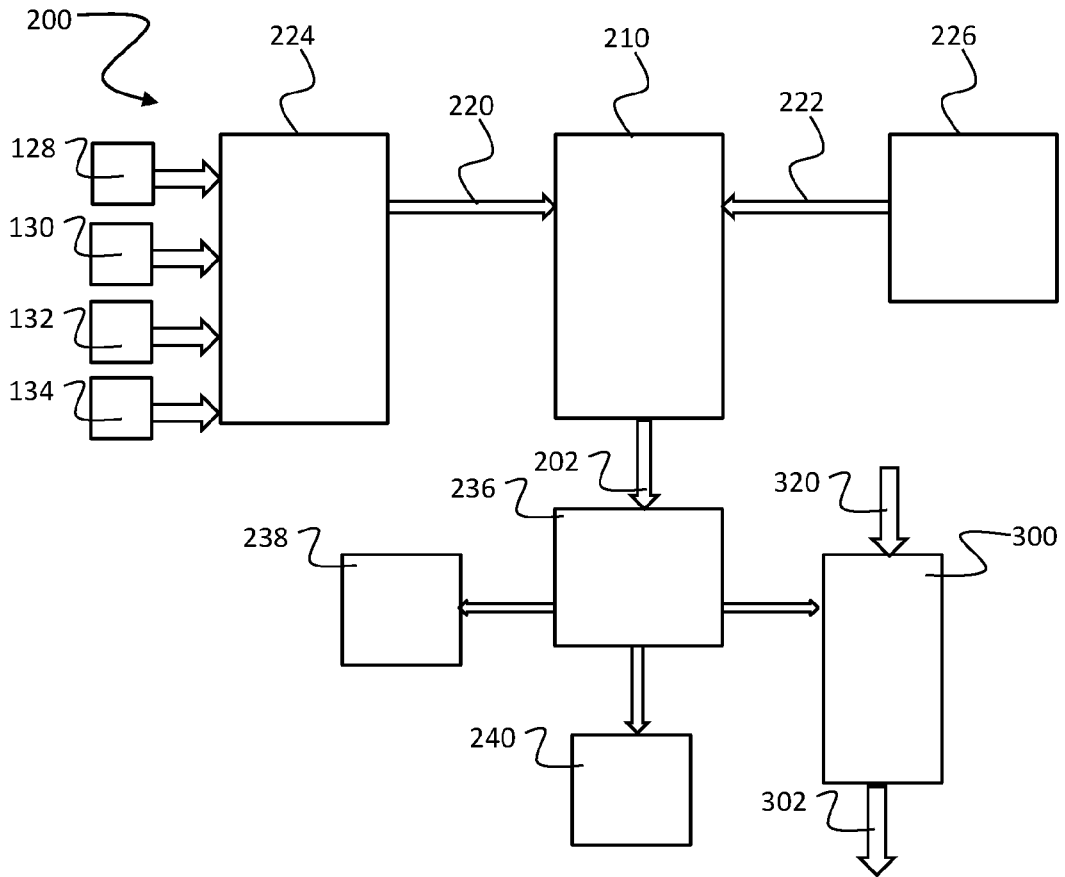

Fig. 2



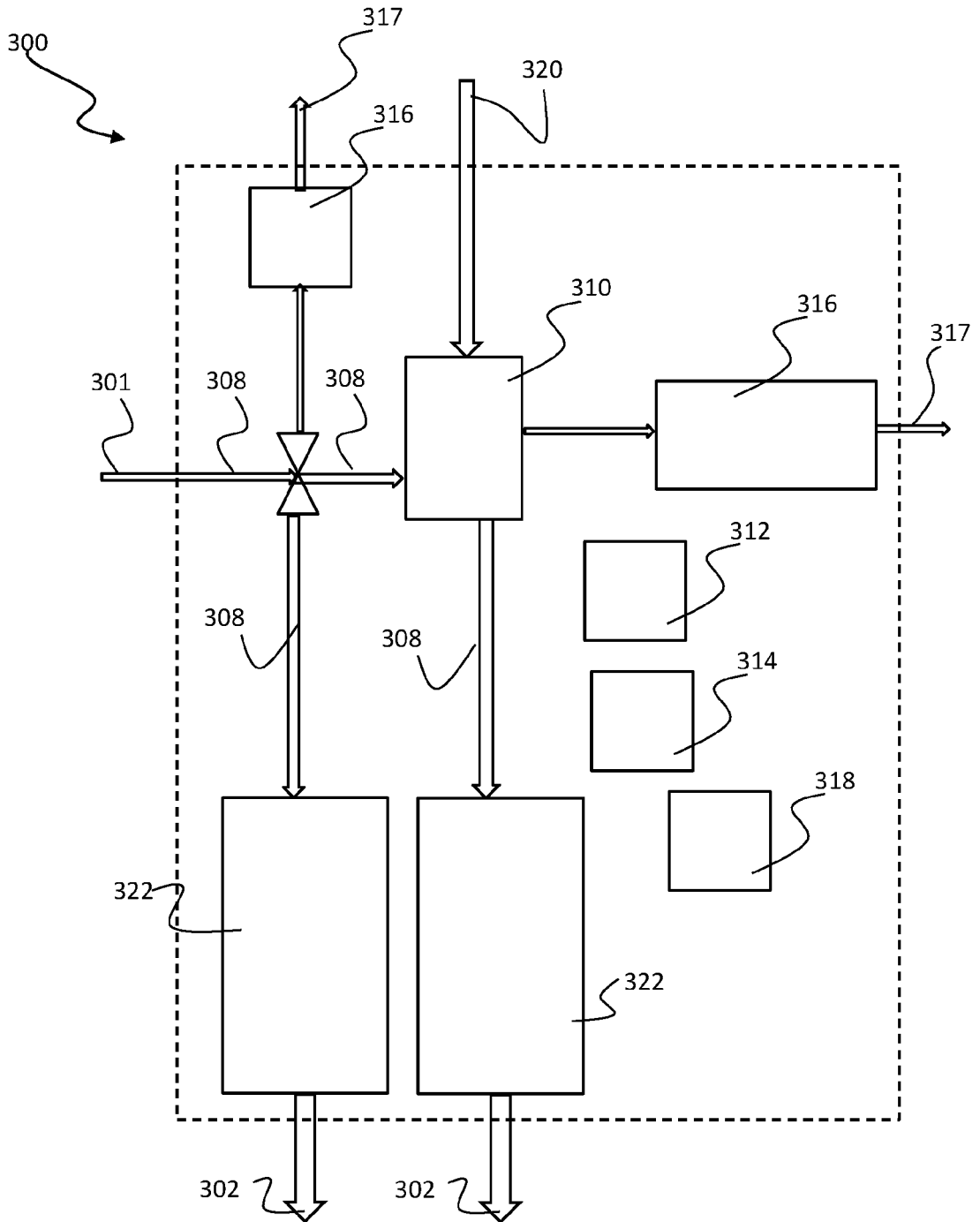

Fig. 3

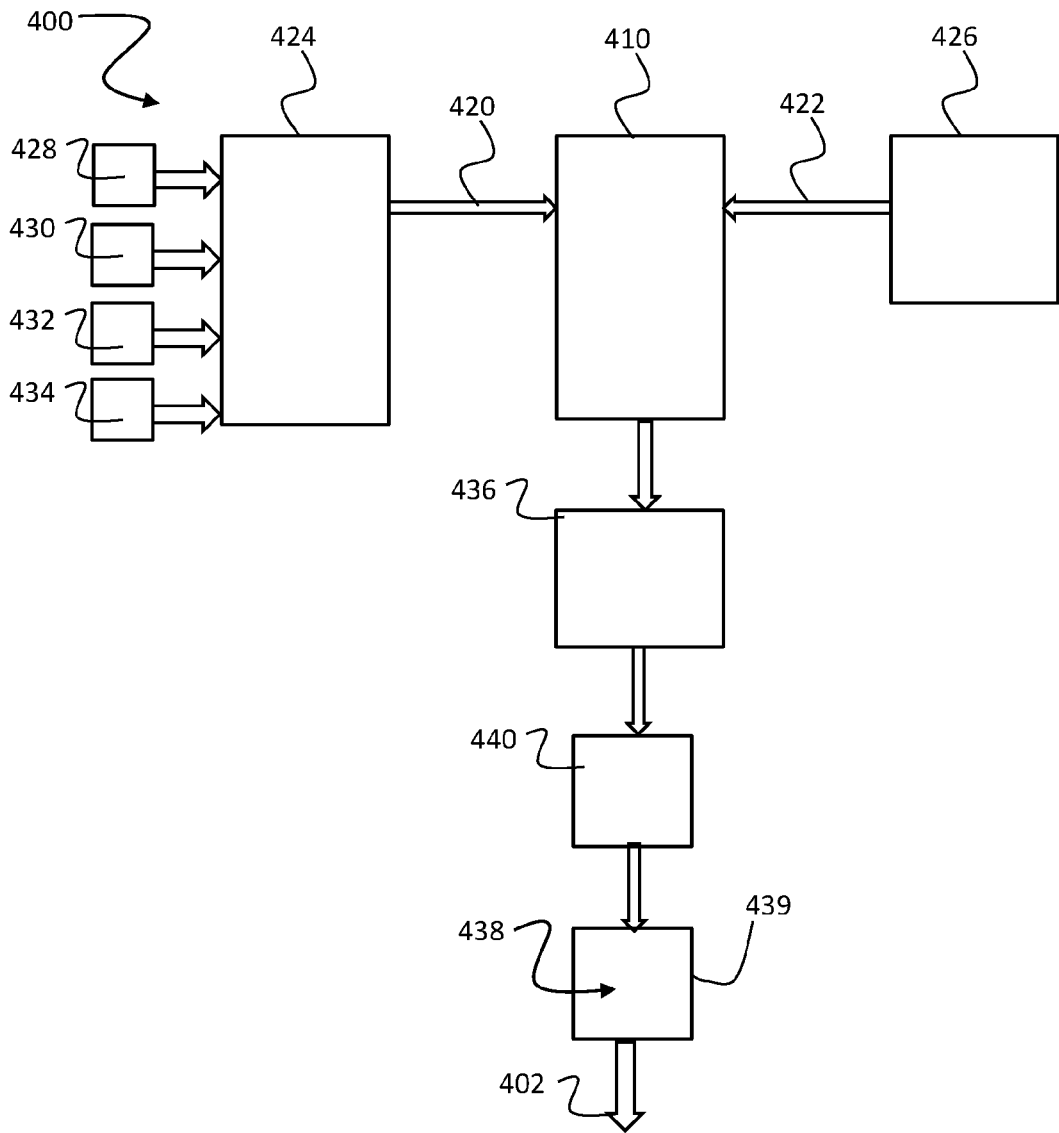

Fig. 4

5/15

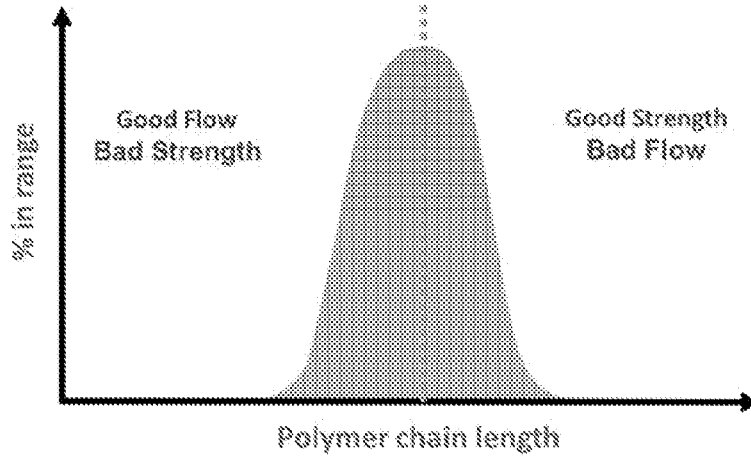

Fig. 5A

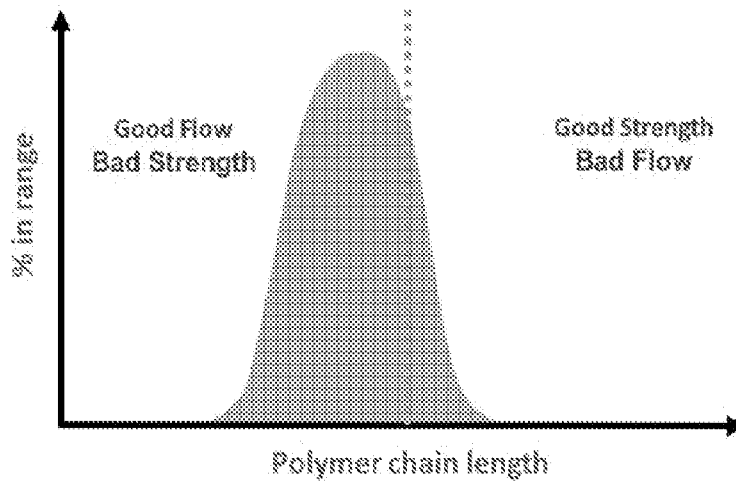

Fig. 5B

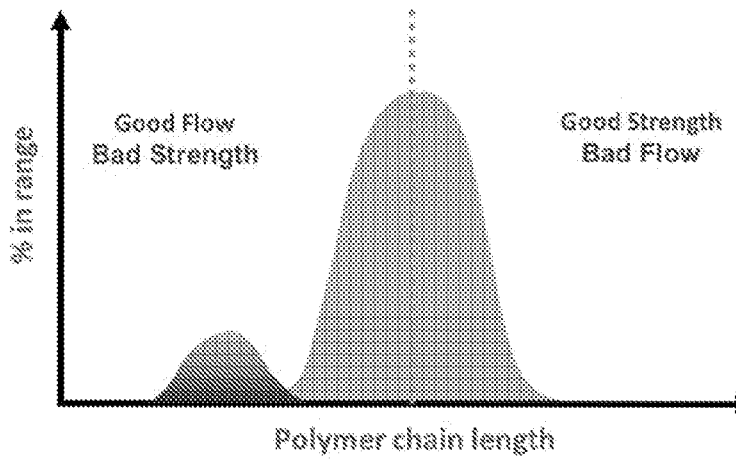

Fig. 5C

6/15

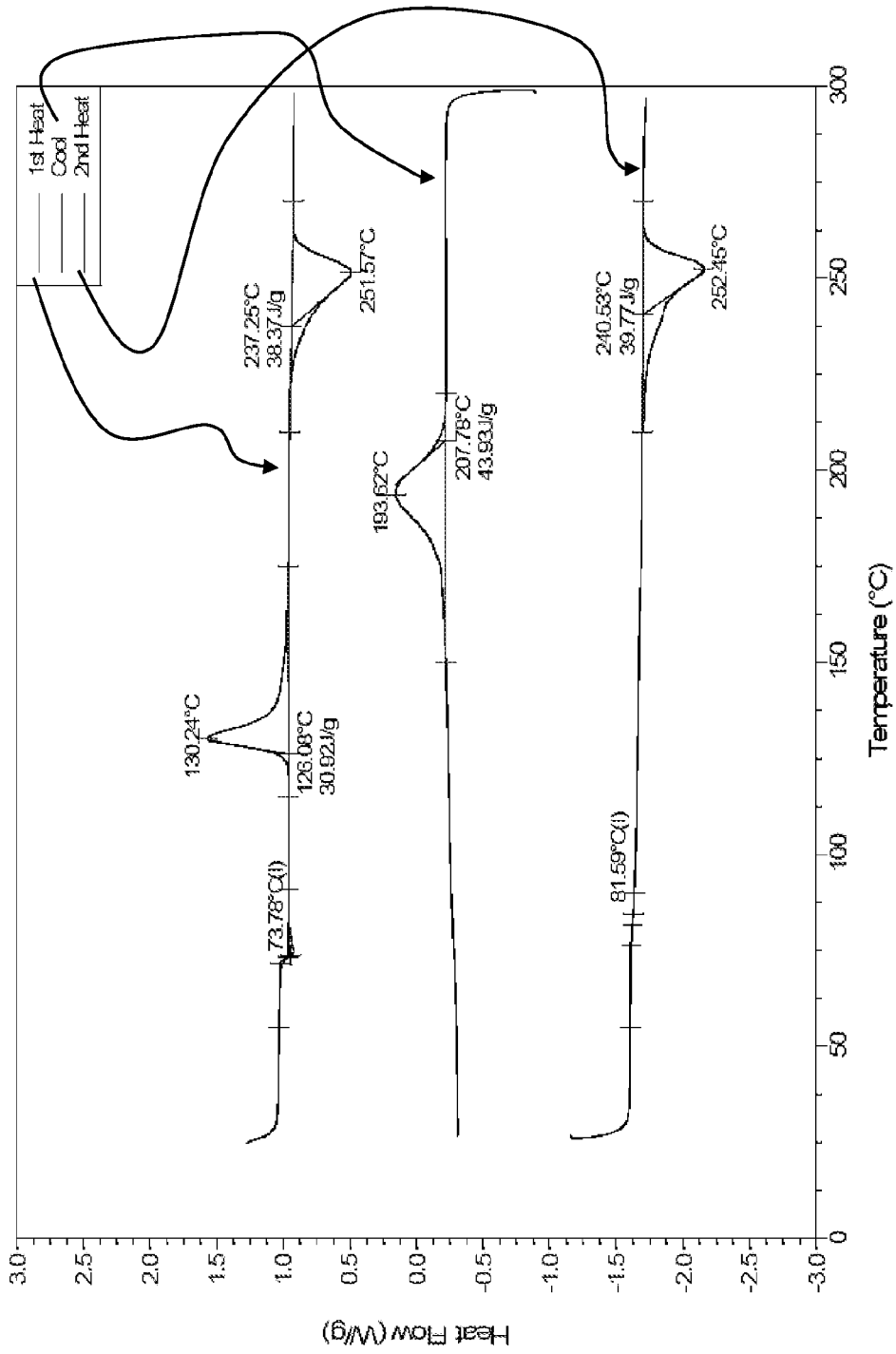

Fig. 6A

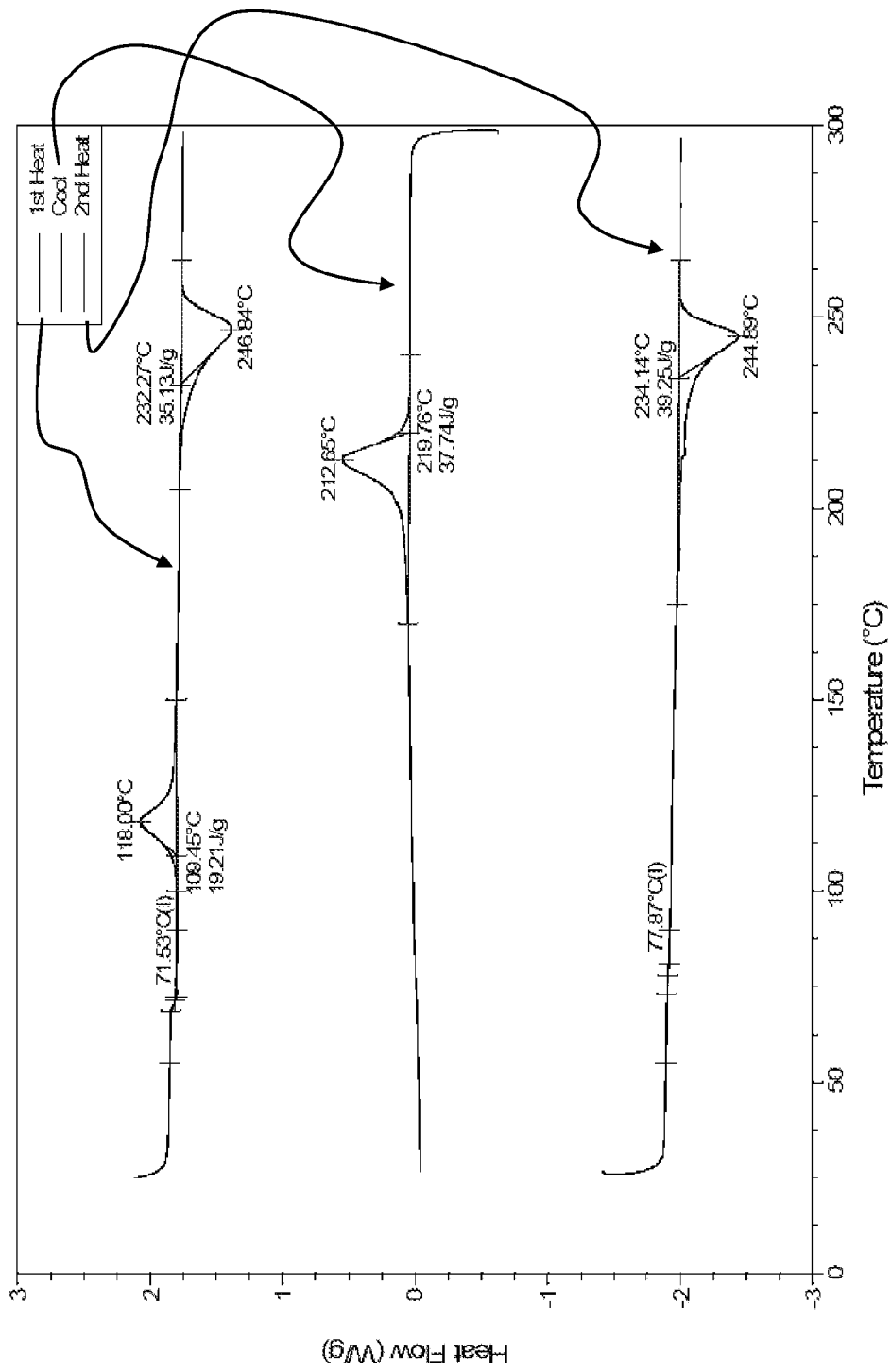

Fig. 6B

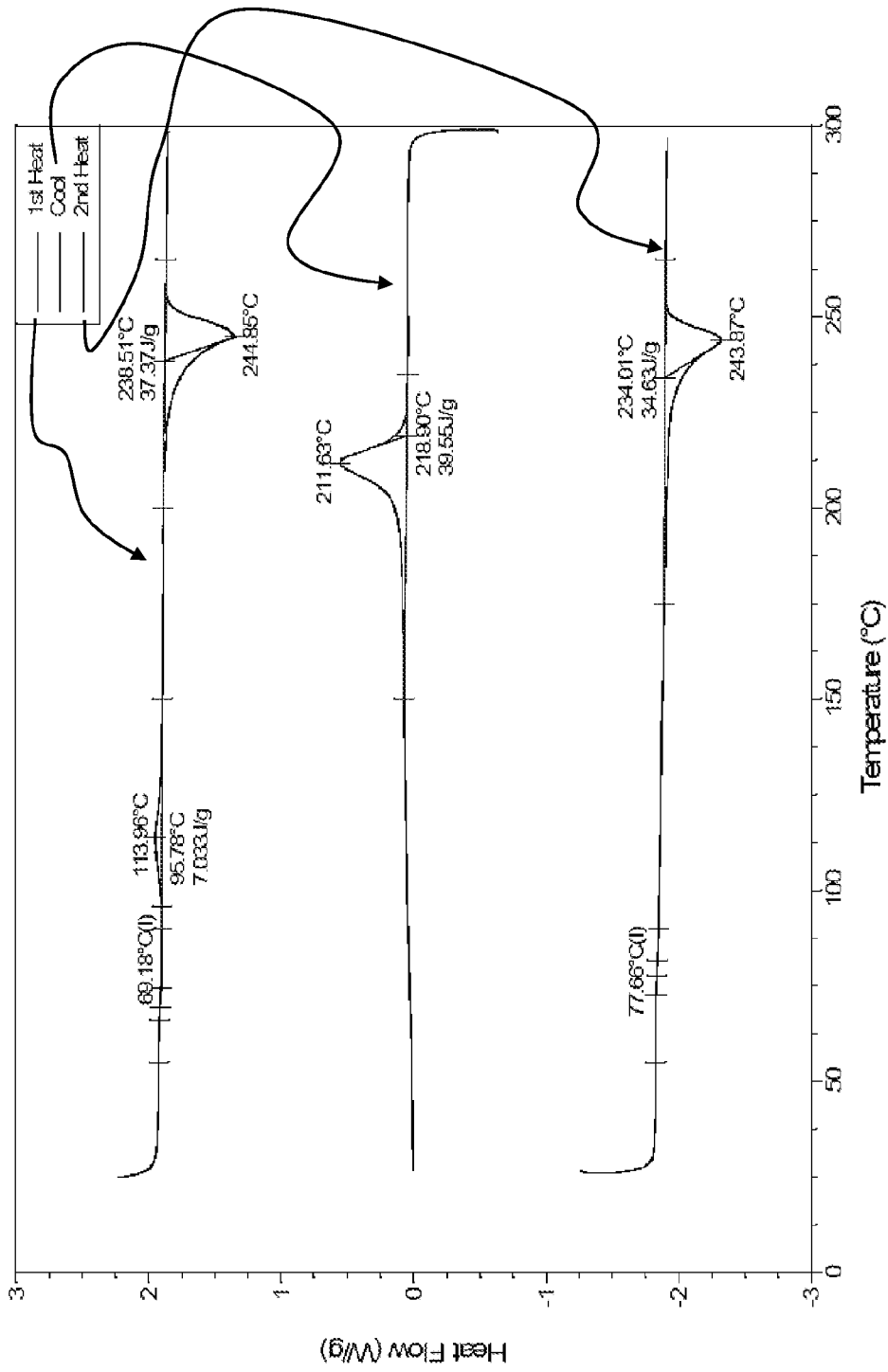

Fig. 6C

9/15

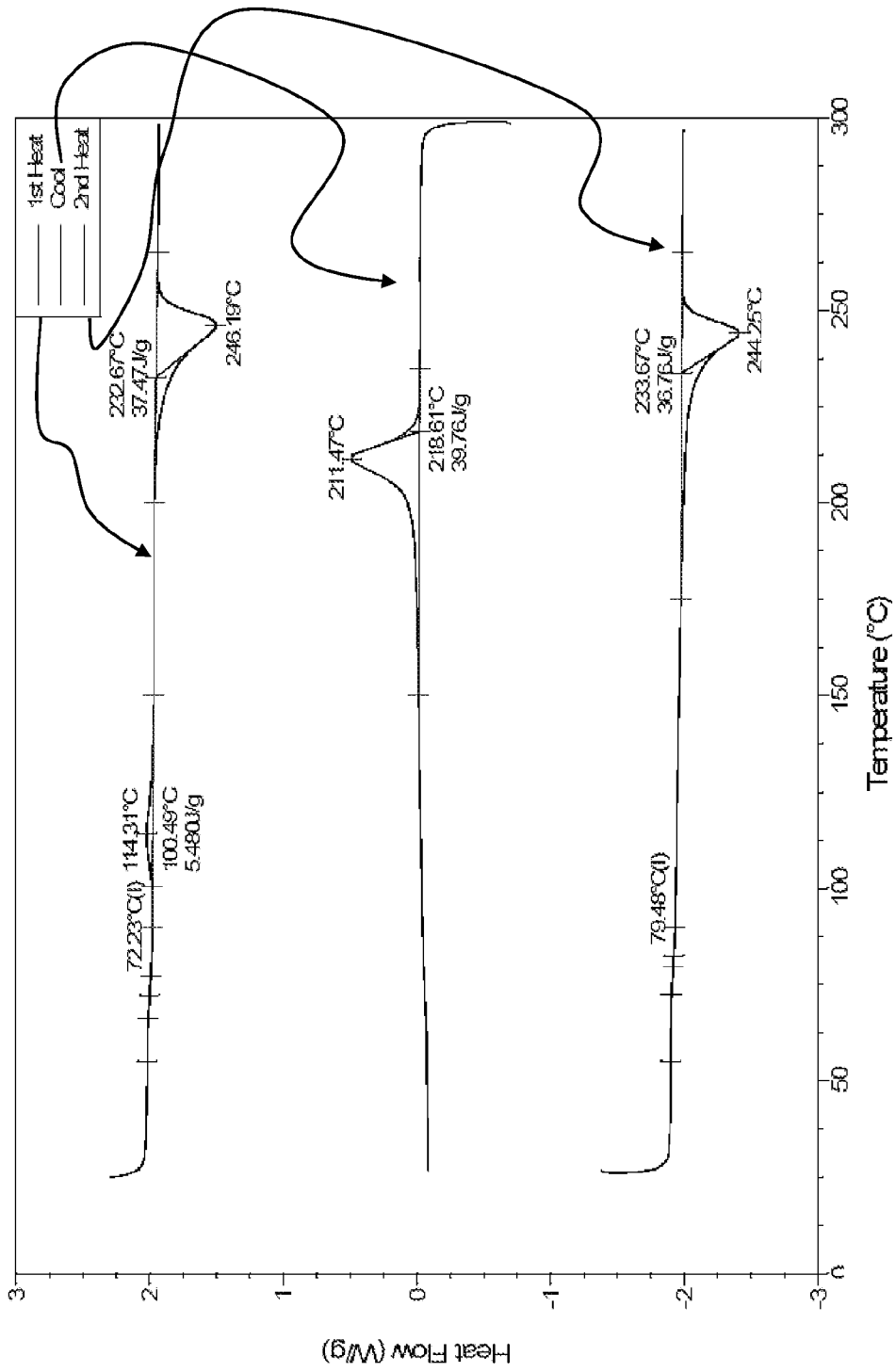

Fig. 6D

10/15

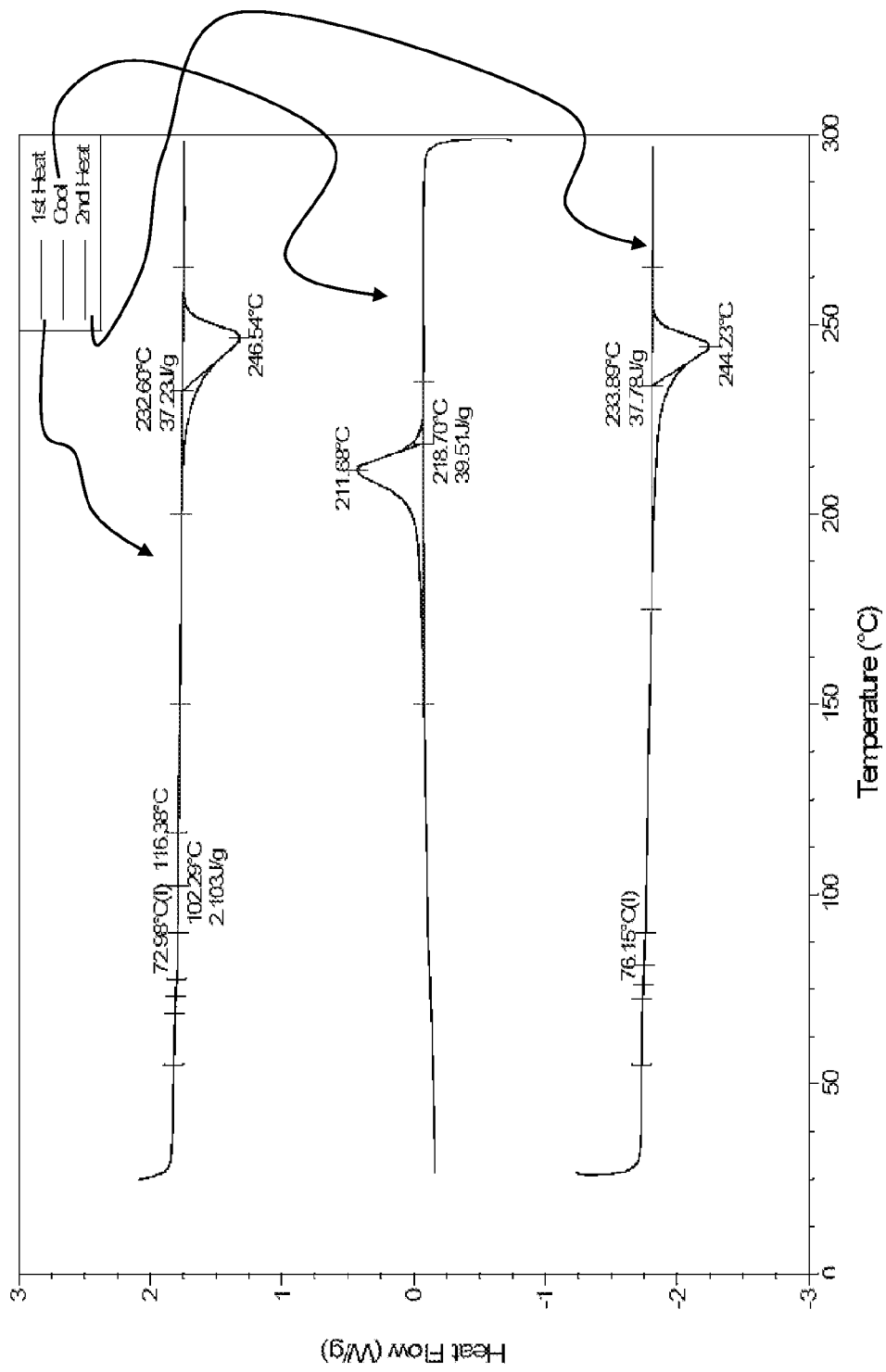

Fig. 6E



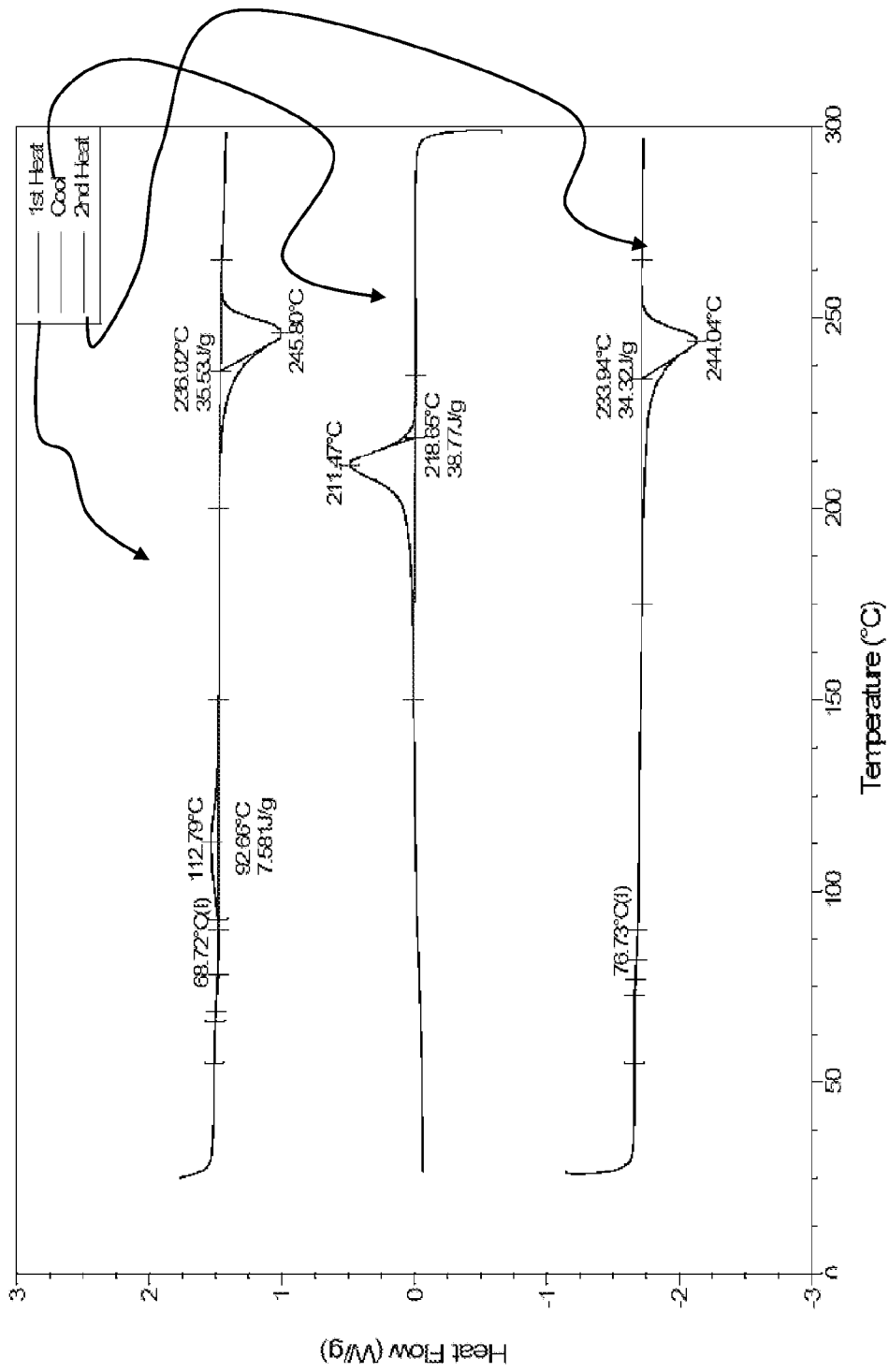

Fig. 6F

		Heat Cycle	$T_g, ^\circ\text{C}$	$T_m, ^\circ\text{C}$	$\Delta H_m, \text{J/g}$	$T_m, ^\circ\text{C}$	$\Delta H_f, \text{J/g}$
PET	{	1 <sup>st</sup> Heat	73.8	130.2	30.9	251.6	38.4
		Cool	---	193.6	43.9	---	---
		2 <sup>nd</sup> Heat	81.6	---	---	252.5	39.8
Talc Filled PET Sheet	{	1 <sup>st</sup> Heat	71.5	118.0	19.2	246.8	35.1
		Cool	---	212.7	37.7	---	---
		2 <sup>nd</sup> Heat	77.9	---	---	244.9	39.3
110 PET Alloy	{	1 <sup>st</sup> Heat	69.2	114.0	7.0	244.9	37.4
		Cool	---	211.6	39.6	---	---
		2 <sup>nd</sup> Heat	77.7	---	---	243.9	34.6
120 PET Alloy	{	1 <sup>st</sup> Heat	72.2	114.3	5.5	246.2	37.5
		Cool	---	211.5	39.8	---	---
		2 <sup>nd</sup> Heat	79.5	---	---	244.3	36.8
125 PET Alloy	{	1 <sup>st</sup> Heat	73.0	116.4	2.1	246.5	37.2
		Cool	---	211.7	39.5	---	---
		2 <sup>nd</sup> Heat	76.2	---	---	244.2	37.8
105 PET Alloy	{	1 <sup>st</sup> Heat	68.7	112.8	7.6	245.8	35.5
		Cool	---	211.5	38.8	---	---
		2 <sup>nd</sup> Heat	76.7	---	---	244.0	34.2

Fig. 7

Test Specimen	OTR (CC/(m <sup>2</sup> ·day))	cc/100 in <sup>2</sup> ·24hr·atm	% lower Vs. control
Control	8.67	0.558	-
VF2	5.64	0.363	35%
VF4	3.6	0.232	58.40%

*VF2 = 10% Talc VF4 = 20% Talc Control = GPO1 sheet*

Fig. 8

	Heat Cycle	T <sub>g</sub> , °C	T <sub>1</sub> , °C	ΔH <sub>1</sub> , J/g	T <sub>m1</sub> , °C	T <sub>m2</sub> , °C	ΔH <sub>2</sub> , J/g	T <sub>2</sub> , °C	ΔH <sub>2</sub> , J/g
PET 20% Talc	1 <sup>st</sup> Heat	75.6	119.9	18.4	N/A	246.8	33.01	N/A	N/A
	Cool	N/A	N/A	N/A	N/A	N/A	N/A	210.7	33.0
	2 <sup>nd</sup> Heat	79.1	N/A	N/A	N/A	243.6	31.7	N/A	N/A
PET	1 <sup>st</sup> Heat	N/A	N/A	N/A	233.2	246.9	55.5	N/A	N/A
	Cool	N/A	N/A	N/A	N/A	N/A	N/A	160.8	21.5
	2 <sup>nd</sup> Heat	80.9	165.9	10.1	N/A	245.2	33.1	N/A	N/A
PET Alloy	1 <sup>st</sup> Heat	N/A	114.8	1.8	232.3	246.3	40.3	N/A	N/A
	Cool	N/A	N/A	N/A	N/A	N/A	N/A	196.6	33.6
	2 <sup>nd</sup> Heat	79.5	N/A	N/A	N/A	244.1	27.5	N/A	N/A

Fig. 9

	Injection	Molar Mass Averages (g/mol)			M <sub>w</sub> /M <sub>n</sub>
		M <sub>n</sub>	M <sub>w</sub>	M <sub>v</sub>	
PET Alloy	1	28,200	75,400	139,000	2.67
	2	28,100	75,800	141,000	2.70
	Average	28,100	75,600	140,000	2.69
	Std. Dev.	110	330	1,500	0.02
PET 20% Talc	1	23,400	48,100	76,000	2.06
	2	23,400	47,700	74,300	2.04
	Average	23,400	47,900	75,100	2.05
	Std. Dev.	10	270	1,180	0.01

Fig. 10

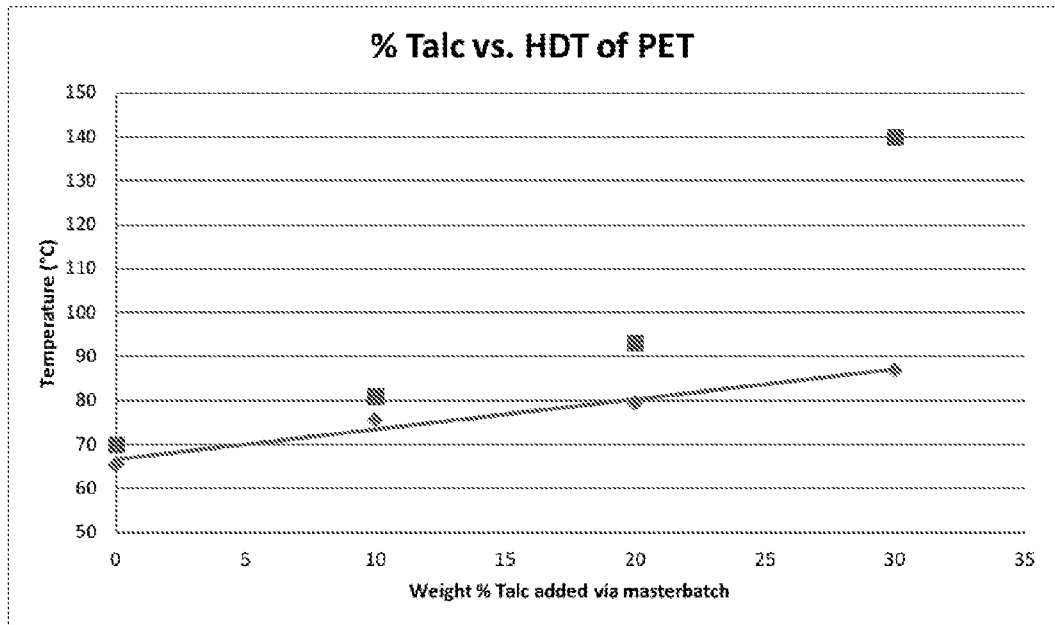

Fig. 11

**PET Alloy**

Specification	Values	Units	Standard used
MFR	31	g/10"	ASTM D 1238
Flex Modulus	715	Kpsi	ASTM D 790
% strain at break	3.83	%	ASTM D638
Flexural Strength	15000	Psi	ASTM D 790
Notched Izod	0.79	Ft-lb/in	ASTM D 256

Fig. 13A

**GPPS RESIN**

Specification	Values	Units	Standard used
MFR	27	g/10"	ASTM D 1238
Flex Modulus	450	Kpsi	ASTM D 790
% strain at break	5	%	ASTM D638
Flexural Strength	10151	Psi	ASTM D 790
Notched Izod	0.4	Ft-lb/in	ASTM D 256

Fig. 13B

PET	100	99	96	96	85	84	83	82	81	81
H05C, latc Dried at 250 F 16 hours	0	0	0	0	15	15	15	15	15	15
CGF	0	1	4	4	0	1	2	3	4	4
HDT (64 psi, n=5, 1/8" bar, 2C/min), C	66	69.5	73.5	76	86	89	92.6	94	96	87
Flexural Modulus, Kpsi		328	405	400	565	604	631	635	654	706
Flexural Modulus, Tangent, Kpsi		333	408	400	589	646	668	685	699	718
Maximum Strain, %		5	5	5	3.1	2.68	2.67	2.47	2.6	2.19
Flexural Strength, psi		10645	12950	12980	13734	13294	13496	13424	14113	13636

Fig. 12

## INTERNATIONAL SEARCH REPORT

International application No.

PCT/US18/31387

A. CLASSIFICATION OF SUBJECT MATTER  
 IPC - C08L 67/02, 69/00, 51/04 (2018.01)  
 CPC - C08L 69/00, 69/055, 67/02

According to International Patent Classification (IPC) or to both national classification and IPC

## B. FIELDS SEARCHED

Minimum documentation searched (classification system followed by classification symbols)

See Search History document

Documentation searched other than minimum documentation to the extent that such documents are included in the fields searched

See Search History document

Electronic data base consulted during the international search (name of data base and, where practicable, search terms used)

See Search History document

## C. DOCUMENTS CONSIDERED TO BE RELEVANT

Category*	Citation of document, with indication, where appropriate, of the relevant passages	Relevant to claim No.
X --- Y	US 2003/0022989 A1 (BRAIG, T, et al.) 30 January 2003; Abstract; Paragraphs [0020], [0025], [0035], [0037], [0093], [0187], [0188], [0205], [0207], [0209], [0214], [0215], [0218], [0226], [0230], [0234], [0256], [0264], [0266], [0267]; Claims 1, 7	1-6, 8, 10-12, 20/1-6, 20/8, 20/10-12, 21/20/1-6, 21/20/8, 21/20/10-12, 22/21/20/1-6, 22/21/20/8, 22/21/20/10-12, 23/20/1-6, 23/20/8, 23/20/10-12, 24/20/1-6, 24/20/8, 24/20/10-12, 25/24/20/1-6, 25/24/20/8, 25/24/20/10-12, 26/20/1-6, 26/20/8, 26/20/10-12, 27/26/20/1-6, 27/26/20/8, 27/26/20/10-12, 28/26/20/1-6, 26/20/8, 26/20/10-12, 29/20/1-6, 29/20/8, 29/20/10-12, 30/20/1-6, 30/20/8, 30/20/10-12, 31/20/1-6, 31/20/8, 31/20/10-12, 32/20/1-6, 32/20/8, 32/20/10-12, 33/20/1-6, 33/20/8, 33/20/10-12, 34/33/20/1-6, 34/20/8, -***-Next Page-***-

Further documents are listed in the continuation of Box C.  See patent family annex.

* Special categories of cited documents:	"T" later document published after the international filing date or priority date and not in conflict with the application but cited to understand the principle or theory underlying the invention
"A" document defining the general state of the art which is not considered to be of particular relevance	"X" document of particular relevance; the claimed invention cannot be considered novel or cannot be considered to involve an inventive step when the document is taken alone
"E" earlier application or patent but published on or after the international filing date	"Y" document of particular relevance; the claimed invention cannot be considered to involve an inventive step when the document is combined with one or more other such documents, such combination being obvious to a person skilled in the art
"L" document which may throw doubts on priority claim(s) or which is cited to establish the publication date of another citation or other special reason (as specified)	"&" document member of the same patent family
"O" document referring to an oral disclosure, use, exhibition or other means	
"P" document published prior to the international filing date but later than the priority date claimed	

Date of the actual completion of the international search

5 July 2018 (05.07.2018)

Date of mailing of the international search report

23 JUL 2018

Name and mailing address of the ISA/

Mail Stop PCT, Attn: ISA/US, Commissioner for Patents  
 P.O. Box 1450, Alexandria, Virginia 22313-1450  
 Facsimile No. 571-273-8300

Authorized officer

Shane Thomas

PCT Helpdesk: 571-272-4300  
 PCT OSP: 571-272-7774

## INTERNATIONAL SEARCH REPORT

International application No.

PCT/US18/31387

## C (Continuation). DOCUMENTS CONSIDERED TO BE RELEVANT

Category*	Citation of document, with indication, where appropriate, of the relevant passages	Relevant to claim No.
X --- Y	<p>----Continued----</p> <p>US 2003/0022989 A1 (BRAIG, T, et al.) 30 January 2003; Abstract; Paragraphs [0020], [0025], [0035], [0037], [0093], [0187], [0188], [0205], [0207], [0209], [0214], [0215], [0218], [0226], [0230], [0234], [0256], [0264], [0266], [0267]; Claims 1, 7</p>	<p>----Continued----</p> <p>34/33/20/10-12, 35/34/33/20/1-6, 35/34/33/20/8, 35/34/33/20/10-12, 36/35/34/33/20/1-6, 36/35/33/20/8, 36/35/33/20/10-12, 37/36/35/34/33/20/1-6, 37/36/35/34/33/20/8, 37/36/35/34/33/20/10-12, 38/37/36/35/34/33/20/1-6, 38/37/36/35/34/33/20/8, 38/37/36/35/34/33/20/10-12, 39/33/20/1-6, 39/33/20/8, 39/33/20/10-12, 40/39/33/20/1-6, 40/39/33/20/8, 40/39/33/20/10-12, 41/33/20/1-6, 41/33/20/8, 41/33/20/10-12, 42/41/33/20/1-6, 42/41/33/20/8, 42/41/33/20/10-12, 43/41/33/20/1-6, 43/41/33/20/8, 43/41/33/20/10-12, 44/43/41/33/20/1-6, 44/43/41/33/20/8, 44/43/41/33/20/10-12, 45/44/43/41/33/20/1-6, 45/44/43/41/33/20/8, 45/44/43/41/33/20/10-12, 46/33/20/1-6, 46/33/20/8, 46/33/20/10-12, 47/33/20/1-6, 47/33/20/8, 47/33/20/10-12, 48/1-6, 48/8, 48/10-12, 49/48/1-6, 49/48/8, 49/48/10-12, 50/49/48/1-6, 50/49/48/8, 50/49/48/10-12, 51/48/1-6, 51/48/8, 51/48/10-12, 52/48/1-6, 52/48/8, 52/48/10-12, 53/48/1-6, 53/48/8, 53/48/10-12, 54/48/1-6, 54/48/8, 54/48/10-12, 56/48/1-6, 56/48/8, 56/48/10-12, 57/20/1-6, 57/20/8, 57/20/10-12, 58/57/20/1-6, 58/57/20/8, 58/57/20/10-12, 61/57/20/1-6, 61/57/20/8, 61/57/20/10-12, 62/57/20/1-6, 62/57/20/8, 62/57/20/10-12, 63/57/20/1-6, 63/57/20/8, 63/57/20/10-12, 64/57/20/1-6, 64/57/20/8, 64/57/20/10-12, 65/57/20/1-6, 65/57/20/8, 65/57/20/10-12, 67/57/20/1-6, 67/57/20/8, 67/57/20/10-12, 68/67/57/20/1-6, 68/67/57/20/8, 68/67/57/20/10-12, ----Next Page----</p>

INTERNATIONAL SEARCH REPORT

International application No.

PCT/US18/31387

C (Continuation). DOCUMENTS CONSIDERED TO BE RELEVANT		
Category*	Citation of document, with indication, where appropriate, of the relevant passages	Relevant to claim No.
X --- Y	<p>----Continued----</p> <p>US 2003/0022989 A1 (BRAIG, T, et al.) 30 January 2003; Abstract; Paragraphs [0020], [0025], [0035], [0037], [0093], [0187], [0188], [0205], [0207], [0209], [0214], [0215], [0218], [0226], [0230], [0234], [0256], [0264], [0266], [0267]; Claims 1, 7</p>	<p>----Continued----</p> <p>69/57/20/1-6, 69/57/20/8, 69/57/20/10-12, 73/57/20/1-6, 73/57/20/8, 73/57/20/10-12, 74/67/57/20/1-6, 74/67/57/20/8, 74/57/20/10-12</p> <p>-----</p> <p>7, 9, 20/7, 20/9, 21/20/7, 21/20/9, 22/21/20/7, 23/20/9, 24/20/7, 25/24/20/7, 25/24/20/9, 26/20/7, 26/20/9, 27/26/20/7, 27/26/20/9, 28/26/20/7, 29/20/7, 29/20/9, 30/20/7, 30/20/9, 31/20/7, 31/20/9, 32/20/7, 32/20/9, 33/20/7, 34/33/20/7, 34/33/20/9, 35/34/33/20/7, 36/35/34/33/20/7, 36/35/34/33/20/9, 37/36/35/34/33/20/7, 37/36/35/34/33/20/9, 38/37/36/35/34/33/20/7, 39/33/20/7, 40/39/33/20/7, 40/39/33/20/9, 41/33/20/7, 41/33/20/9, 42/41/33/20/7, 42/41/33/20/9, 43/41/33/20/7, 43/41/33/20/9, 44/43/41/33/20/7, 44/43/41/33/20/9, 45/44/43/41/33/20/7, 45/44/41/33/20/9, 46/33/20/7, 46/33/20/9, 47/33/20/7, 47/33/20/9, 48/7, 48/9, 49/48/7, 49/48/9, 50/49/48, 50/49/48/9, 51/48/7, 51/48/9, 52/48/7, 52/48/9, 53/48/7, 53/48/9, 54/48/7, 54/48/9, 55/48/1-12, 56/48/7, 56/48/9, 57/20/1-12, 58/57/20/1-12, 59/57/20/1-12, 60/57/20/1-12, 61/57/20/1-12, 62/57/20/1-12, 63/57/20/1-12, 64/57/20/1-12, 65/57/20/1-12, 66/57/20/1-12, 68/67/57/20/1-12, 69/57/20/1-12, 70/57/20/1-12, 71/57/20/1-12, 72/57/20/1-12, 73/57/20/1-12, 74/67/57/20/1-12</p>
Y	<p>US 7,655,291 B2 (YE, Y) 02 February 2010; Abstract; Claims 1, 2</p> <p>----Next Page----</p>	<p>7, 20/7, 21/20/7, 22/21/20/7, 23/20/7, 24/20/7, 25/24/20/7, 26/20/7, 27/26/20/7, 2</p> <p>----Next Page----</p>



INTERNATIONAL SEARCH REPORT

International application No.

PCT/US18/31387

C (Continuation) DOCUMENTS CONSIDERED TO BE RELEVANT		
Category*	Citation of document, with indication, where appropriate, of the relevant passages	Relevant to claim No.
Y	<p>***-Continued-***                      US 7,655,291 B2 (YE, Y) 02 February 2010; Abstract; Claims 1, 2</p>	<p>***-Continued-***                      8/26/20/7, 29/20/7,                      30/20/7, 31/20/7, 32/20/7,                      33/20/7, 34/33/20/7,                      35/34/33/20/7,                      36/35/34/33/20/7,                      37/36/35/34/33/20/7,                      38/37/36/35/34/33/20/7,                      39/33/20/7,                      40/39/33/20/7,                      41/33/20/7,                      42/41/33/20/7,                      43/41/33/20/7,                      44/43/41/33/20/7,                      45/44/43/41/33/20/7,                      46/33/20/7, 47/33/20/7,                      48/7, 49/48/7, 50/49/48,                      51/48/7, 52/48/7, 53/48/7,                      54/48/7, 56/48/7, 57/20/7,                      58/57/20/7, 59/57/20/7,                      61/57/20/7, 62/57/20/7,                      63/57/20/7, 64/57/20/7,                      65/57/20/7,                      67/57/20/7,                      68/67/57/20/7,                      69/57/20/7, 70/57/20/7,                      71/57/20/7, 72/57/20/7,                      73/57/20/7, 74/67/57/20/7</p>
Y	<p>US 8,969,433 B2 (SABIC INNOVATIVE PLASTICS IP B.V.) 03 March 2015; Abstract; Column 10, Lines 48-50</p>	<p>9, 20/9, 21/20/9, 23/20/9,                      24/20/9, 25/24/20/9,                      26/20/9, 27/26/9,                      28/26/20/9, 29/20/9,                      30/20/9, 31/20/9, 32/20/9,                      33/20/9, 34/33/20/9,                      35/34/33/20/9,                      36/35/34/33/20/9,                      37/36/35/34/33/20/9,                      38/37/36/35/34/33/20/9,                      39/33/20/9,                      40/39/33/20/9,                      41/33/20/9,                      42/41/33/20/9,                      43/41/33/20/9,                      44/43/41/33/20/9,                      45/44/41/33/20/9,                      46/33/20/9, 47/33/20/9,                      48/9, 49/48/9, 50/49/48/9,                      51/48/9, 52/48/9, 53/48/9,                      54/48/9, 55/48/9, 56/48/9,                      57/20/9, 58/57/20/9,                      59/57/20/9, 60/57/20/9,                      61/57/20/9, 62/57/20/9,                      63/57/20/9, 64/57/20/9,                      65/57/20/9, 67/57/20/9,                      68/67/57/20/9,                      69/67/57/20/9,                      70/57/20/9, 71/57/20/9,                      72/57/20/9, 73/57/20/9,                      74/67/57/20/9</p>
Y	<p>(JIANG, XL, et al.) Effect of Nucleating Agents on Crystallization Kinetics of PET. eXPRESS Polymer Letters. 07 April 2007, Vol. 1, No. 4; Pages 245-251; Abstract; Page 245, Left Column, First Paragraph to Page 245, Left Column, Second Paragraph; Page 249, Left Column, Table 2; Table 2 - caption; DOI: 10.3144/expresspolymlett.2007.37.</p>	<p>55/48/1-12,                      66/57/20/1-12</p>
Y	<p>US 2014/350139 A1 (ADEKA CORPORATION) 27 November 2014; Abstract; Paragraphs [0004], [0035], [0052], [0053]                      ***-Continued on Next Page-***</p>	<p>59/57/20/1-12,                      60/57/20/1-12                      ***-Next Page-***</p>

INTERNATIONAL SEARCH REPORT

International application No.

PCT/US18/31387

C (Continuation). DOCUMENTS CONSIDERED TO BE RELEVANT

Category*	Citation of document, with indication, where appropriate, of the relevant passages	Relevant to claim No.
Y	<p>***-Continued-***</p> <p>(BUNTINX, M, et al.) Evaluation of the Thickness and Oxygen Transmission Rate Before and After Thermoforming Mono- and Multi-Layer Sheets into Trays with Variable Depths. <i>Polymers</i>. 22 December 2014, Vol. 6, No. 12; Pages 3019-3042; Abstract; Page 3031, Table 4; Page 3031, Paragraphs 1-3; DOI: 10.3390/polym6123019. ISSN 2073-4360.</p>	<p>***-Continued-***</p> <p>70/57/201-12, 71/57/201-12, 72/57/201-12</p>

INTERNATIONAL SEARCH REPORT

International application No.

PCT/US18/31387

**Box No. II Observations where certain claims were found unsearchable (Continuation of item 2 of first sheet)**

This international search report has not been established in respect of certain claims under Article 17(2)(a) for the following reasons:

1.  Claims Nos.:  
because they relate to subject matter not required to be searched by this Authority, namely:
  
2.  Claims Nos.:  
because they relate to parts of the international application that do not comply with the prescribed requirements to such an extent that no meaningful international search can be carried out, specifically:
  
3.  Claims Nos.: 13-19  
because they are dependent claims and are not drafted in accordance with the second and third sentences of Rule 6.4(a).

**Box No. III Observations where unity of invention is lacking (Continuation of item 3 of first sheet)**

This International Searching Authority found multiple inventions in this international application, as follows:

1.  As all required additional search fees were timely paid by the applicant, this international search report covers all searchable claims.
2.  As all searchable claims could be searched without effort justifying additional fees, this Authority did not invite payment of additional fees.
3.  As only some of the required additional search fees were timely paid by the applicant, this international search report covers only those claims for which fees were paid, specifically claims Nos.:
  
4.  No required additional search fees were timely paid by the applicant. Consequently, this international search report is restricted to the invention first mentioned in the claims; it is covered by claims Nos.:

- Remark on Protest**
- The additional search fees were accompanied by the applicant's protest and, where applicable, the payment of a protest fee.
  - The additional search fees were accompanied by the applicant's protest but the applicable protest fee was not paid within the time limit specified in the invitation.
  - No protest accompanied the payment of additional search fees.